

LP-2340 and LP-2360 PoE and Ethernet Extenders

- Extends the incoming Data AND PoE Power 328ft/100mtr
- Powered by incoming PoE Power (no local PSU required)
- Compact Design
- Extended Operating Temperature
- Cost Effective vs alternative Solutions



LP-2340 - INTERNAL



LP-2360 - EXTERNAL

The LAN-Power **LP-2340** and **LP-2360** PoE and Ethernet Data Segment Extenders enable the extension of both Power over Ethernet (PoE) and Ethernet Data, over standard CAT 5 (or above) cabling, beyond the specified 328 feet (100 meter) lengths for 10/100Base T Networks. They forward both PoE Power and Ethernet Data for one additional 328 feet (100 meter) segment per installed unit. Multiple units can be installed in series for longer distance applications, with no degradation in network speed or added latency. The **LP-2340** is designed for internal applications and the **LP-2360**, with its weather-resistant enclosure (IP 67 Rated), is designed for external applications. The LP-2360 includes back plate mounting bracket and three (3) external wiring grommets.

Both units are capable of being powered by a remote PoE Midspan device or Ethernet Switch with standard PoE power and require no separate power connection in the local cable segment. (Note: up to 2 units maximum in a single channel.) This makes it extremely easy and cost effective to connect and power IP devices, such as IP Cameras, at distances further than previously possible and without the need for costly Fiber cabling and/or remote power sources.

The **LP-2340** and **LP-2360** use 2 Watts max of incoming PoE power to operate. Once two units have been installed in the Ethernet segment, the **LP-2340** and **LP-2360** can use an optional **LP-2340PSU (Power Supply Unit)** which will then boost the PoE Power Output to span 3 additional 100m segments. Both units have diagnostic LEDs showing status of unit power, Data links and activity on each port.

Application Overviews

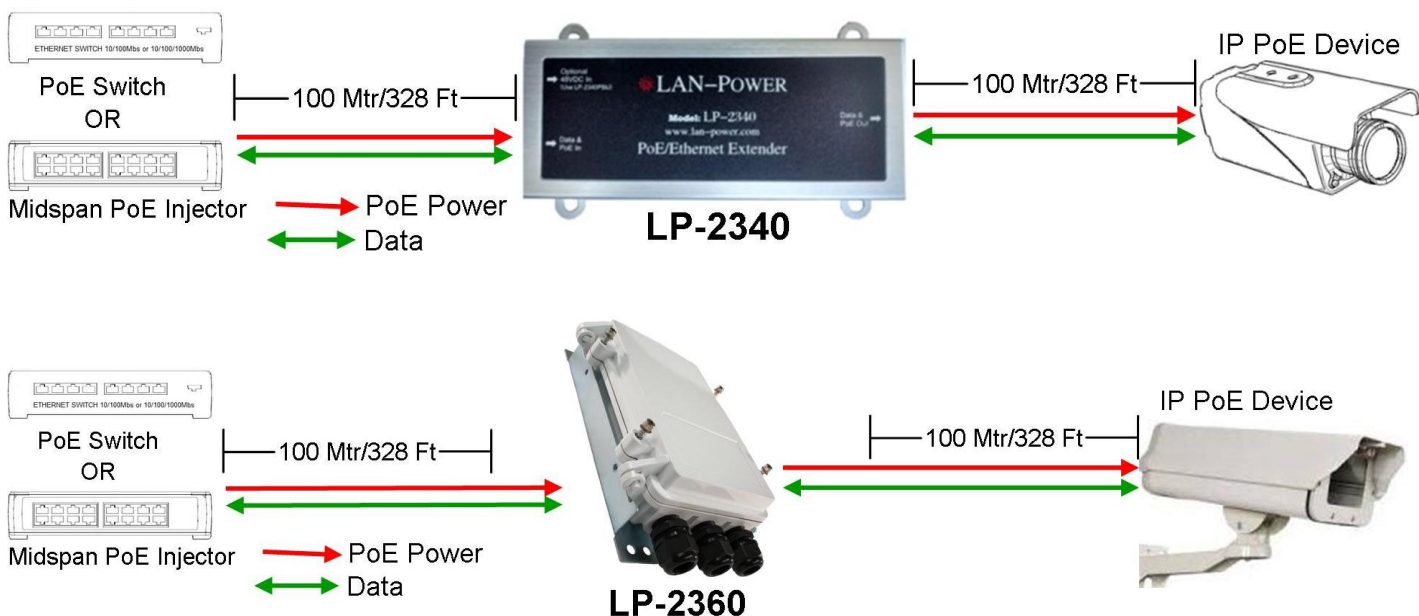

1,100 Meters Maximum Segment length using LP-2340PSU with every 3rd LP-2340 or LP-2360

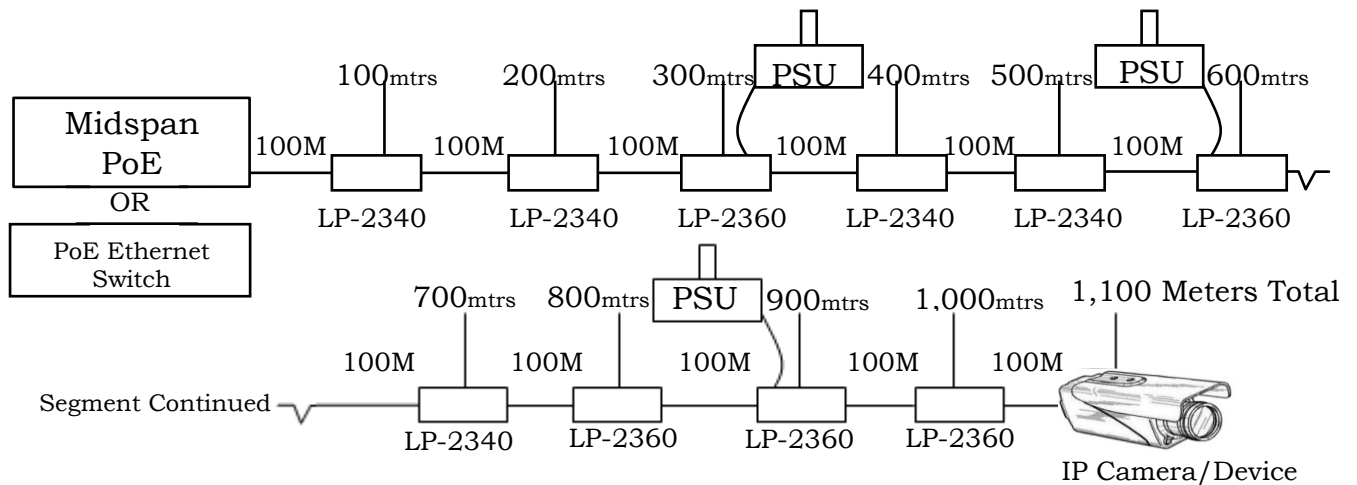

LP-2340 and LP-2360 Technical Specifications

Ethernet Connectors:

RJ45 x 2:

- Data/PoE Input
- Data/PoE Output

Cable Type: UTP LAN Data Cabling
Category 5 or better

Data Rates: 10Mb or 100Mb Full Duplex

LED Indicators:

Power-Amber: Unit receiving PoE or LP2340PSU Power and able to forward PoE

Link & Data Transfer-Green Flashing:

Network connection present from IP End Device and to Ethernet Switch with 10/100Mbs Data

POWER

Unit power: 2 watts maximum, taken From PoE switch or Midspan or OPTIONAL Accessory Mains Power Supply (LP-2340PSU)

PoE Forwarding: Complies with 802.3af
PoE standard

PoE Wattage: Origination amount less 2 less watts per LP-2340/ LP-2360 unit

ENVIRONMENTAL

Operating Temp: LP2340 = -30° C to 55° C

Operating Temp: LP2360 = -30° C to 65° C

Relative Humidity: 95% non-condensing

LP-2340 Dimensions: 4"(L) x 1 3/5"(W) x 4/5"(H)

LP-2340 Weight: 4oz

LP-2360 Dimensions: 11 4/5"(L) x 7 1/4"(W) x 3 1/4"(H)

LP-2360 Weight: 6 1/4 Lbs.

Compliance: CE, FCC, RoHS



Product Ordering Information

LP-2340 PoE and Ethernet Segment Extender – Internal Use

LP-2360 PoE and Ethernet Segment Extender - External Use

LP-2340PSU Optional Accessory Mains Power Supply Unit Supply
(use to power LP-2340 and/or LP-2360 and boost PoE output to 30 Watts)