



Product Data Sheet

IM Series: IM-612 (UT-612)

6 Volt, 1.2 Amp. Hour

Specifications

Rated Voltage	6V	
Nominal Capacity	1.2Ah	(C ₂₀ , 1.75V/cell, 20hrs)
Dimensions	Length	3.82 inches (97mm)
	Width	0.94 inches (24mm)
	Container Height	2.03 inches (51.5mm)
	Total Height	2.26 inches (57.5mm)
Approx Weight	0.60 lbs (0.27 Kg)	
Terminal	F1	
Container Material	ABS	
Rated Capacity (25°C)	1.20 Ah	(20hr, 0.060A, 1.75V/cell)
	1.13 Ah	(10hr, 0.113A, 1.75V/cell)
	1.04 Ah	(5hr, 0.207A, 1.75V/cell)
	0.918 Ah	(3hr, 0.306A, 1.75V/cell)
	0.789 Ah	(1hr, 0.789A, 1.60V/cell)
Max. Discharge Current	18A (5s)	
Internal Resistance (25°C)	Approx 65mΩ	
Operating Temp. Range	Discharge	5 ~ 122°F (-15 ~ 50°C)
	Charge	-4 ~ 104°F (-20 ~ 40°C)
	Storage	5 ~ 104°F (-15 ~ 40°C)
Nominal Operating Temp. Range	77±5°F (25±3°C)	
Standby/Float Use	Initial Charging Current less than 0.36A. Voltage	
	6.75V~6.90V at 77°F(25°C)Temp. Coefficient -5mV/°F	
Temperature Effect on Capacity	104°F (40°C)	103%
	77°F (25°C)	100%
	32°F (0°C)	86%
Self Discharge	IM series batteries may be stored for up to 6 months	
	at 77°F(25°C) and then a freshening charge is required. For higher temperatures - time interval will be shorter.	



Layout

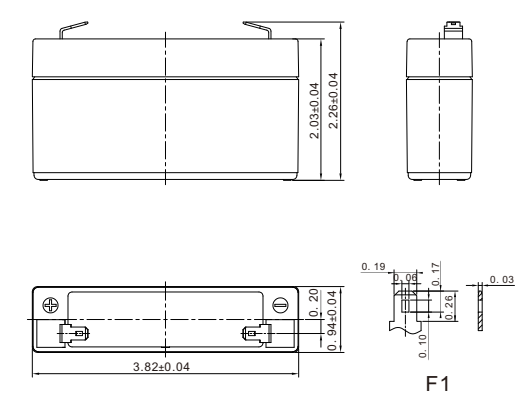

Constant Current Discharge (Amperes) at 77°F(25 °C)

F.V/Time	5min	10min	15min	20min	30min	45min	1h	1.5h	2h	3h	4h	5h	6h	8h	10h	20h
1.85V/cell	3.73	2.28	1.78	1.48	1.10	0.813	0.714	0.523	0.411	0.296	0.236	0.201	0.172	0.136	0.111	0.059
1.80V/cell	4.01	2.42	1.86	1.54	1.14	0.835	0.731	0.534	0.418	0.301	0.240	0.204	0.175	0.138	0.112	0.059
1.75V/cell	4.23	2.52	1.92	1.59	1.17	0.853	0.746	0.543	0.426	0.306	0.243	0.207	0.177	0.139	0.113	0.060
1.70V/cell	4.43	2.62	1.99	1.63	1.20	0.872	0.760	0.553	0.432	0.311	0.246	0.209	0.179	0.141	0.115	0.060
1.67V/cell	4.58	2.69	2.04	1.67	1.22	0.886	0.771	0.560	0.437	0.314	0.249	0.211	0.181	0.142	0.115	0.061
1.60V/cell	4.86	2.80	2.11	1.72	1.25	0.908	0.789	0.572	0.446	0.319	0.253	0.215	0.183	0.144	0.117	0.062

C.O.V - Cutoff Voltage/cell. The battery is fully charged & being discharged to COV

Constant Power Discharge (Watts/cell) at 77°F(25 °C)

F.V/Time	5min	10min	15min	20min	30min	45min	1h	1.5h	2h	3h	4h	5h	6h	8h	10h	20h
1.85V/cell	7.06	4.34	3.40	2.86	2.13	1.58	1.39	1.02	0.804	0.583	0.465	0.397	0.341	0.269	0.220	0.117
1.80V/cell	7.52	4.57	3.55	2.96	2.19	1.61	1.42	1.04	0.817	0.591	0.471	0.402	0.345	0.273	0.223	0.119
1.75V/cell	7.84	4.72	3.64	3.02	2.23	1.64	1.44	1.05	0.830	0.599	0.477	0.407	0.349	0.275	0.225	0.120
1.70V/cell	8.13	4.87	3.74	3.09	2.28	1.67	1.46	1.07	0.840	0.607	0.483	0.412	0.353	0.278	0.227	0.121
1.67V/cell	8.34	4.98	3.82	3.15	2.32	1.70	1.48	1.08	0.848	0.612	0.487	0.415	0.356	0.280	0.229	0.122
1.60V/cell	8.68	5.13	3.92	3.23	2.37	1.73	1.51	1.10	0.862	0.621	0.494	0.420	0.360	0.284	0.232	0.123

C.O.V - Cutoff Voltage/cell. The battery is fully charged & being discharged to COV



Product Data Sheet

IM Series: IM-612 (UT-612)

6 Volt, 1.2 Amp. Hour

Applications

- All purpose
- Uninterruptable Power Supply (UPS)
- Electric Power System (EPS)
- Emergency backup power supply
- Alarm and security system
- Communication power supply
- DC power supply
- Auto control system

General Features

- 5 years design life(77°F)
- Special exhaust structure and sealing technology, safe and reliable, flexible installation, convenient maintenance
- High purity PbCaSn raw material alloy is used for plate grids, assuring less gassing & low self-discharge rate
- High quality AGM separator: extend cycle life and prevent micro short circuit

Standards

- Compliance with IEC 60896 standards, EU Battery Directive
- UL, CE Certified
- Manufactured in IATF16949,ISO45001, ISO 9001 and ISO 14001 certified production facilities



Discharge Characteristics

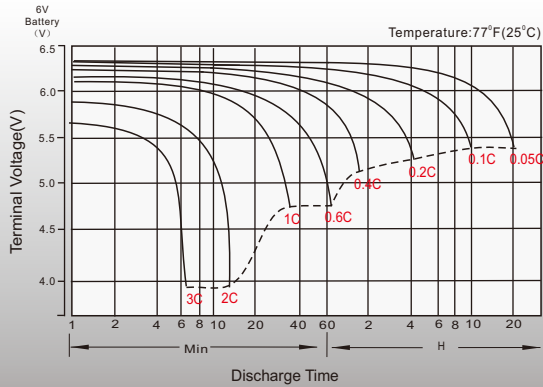

Curves represent Constant Current draw (Amp.)
 1C curve = 1 x Nominal capacity = 1.2amp. constant draw 0.05C curve = 0.05 x Nominal capacity = 0.06amp. draw

Standby/Float Charging Characteristics

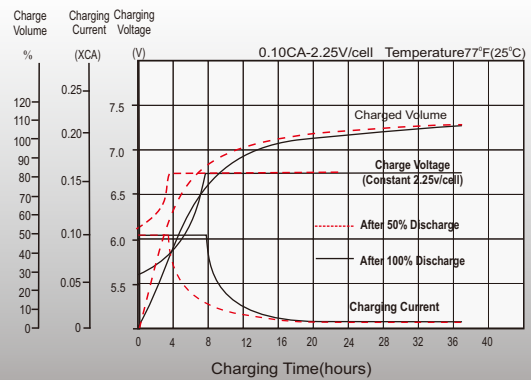

Temperature Effectes on Battery Capacity

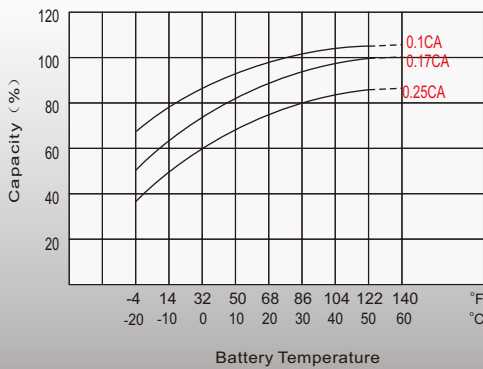

Temperature Effectes on Long Term Float Life

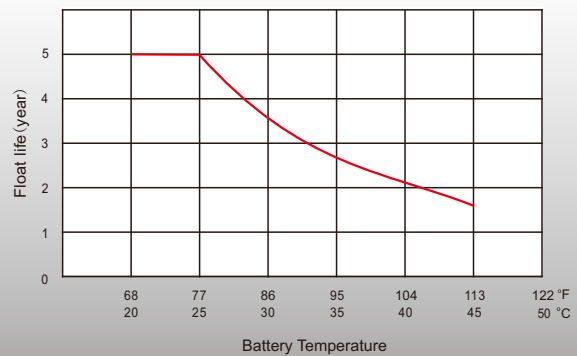

Sales Offices

Sales: 1.800.233.6261

Website: www.adiglobaldistribution.us
www.adiglobaldistribution.ca