

SERIES 27000



Horizontal DETECT-A-FIRE® Units Installation Instructions

12.02.E

INSTALLATION

Model Number	Contact Operation on Temperature Rise	Electrical Rating (Resistive Only)
27020-0	Opens	5.0 Amps 125 VAC
27020-1		0.5 Amps 125 VDC
27021-0	Closes	5.0 Amps 126 VAC
27021-1		0.5 Amps 125 VDC 2.0 Amps 24 VDC 1.0 Amps 48 VDC

Note: Although incandescent lamps are considered resistive, their inrush current is 10-15 times their stead current. Do not exceed ratings.

LOCATION

DETECT-A-FIRE® detectors are precision temperature sensors. They must be mounted in an area (normally a ceiling) so that:

1. The detector spacing complies with both system requirements and requirements of the agency having local jurisdiction.
2. The thermal air path to the shell is not obstructed.

Spacing per UL, FM, and UL of Canada is show in Table 1. Distances given are for between units on smooth ceilings. Distances from partitions or walls are half that shown. To assume that all spacing requirements are met, consult the authority having local jurisdiction.

MOUNTING

DETECT-A-FIRE units are not position sensitive. Horizontal and vertical detectors refer to the most common mounting configurations for that unit. However, each type can be mounted either horizontally or vertically depending on the application and installation requirements.

TABLE 1: Model Number 27120*, 27121

X	°F Setting	°F Tolerance	Spacings (in feet)			RTI	Color Coding
			UL	ULc	FM		
A	140	+7/-8	50	50	20	Quick	Black
A	160	+7/-8	25	25	20	Quick	Black
A	190	+7/-8	50	50	25	Fast	White
A	210	+7/-8	25	50	25	Fast	White
A	225	+7/-8	25	50	25	Fast	White
B	275	±10	25	50	25	Fast	Blue
B	325	±10	50	50	25	Fast	Red

*27120 is a normally closed device and does not meet the requirements of NFPA-72 for use as an initiating device.

Figure 1. Surface Mount Units (Series 27020-1 and 27021-1)

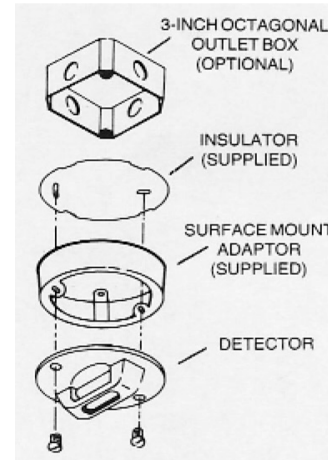

These detectors are provided with a surface mount adaptor which may be mounted on a ceiling or to an outlet box. However, if the adaptor is direct ceiling mounted, CIRCUIT VOLTAGE MUST BE LIMITED TO 30 VOLTS.

The Canadian Electrical Code, Part 1, requires that these devices be installed, mounted to an approved outlet box and connected to Class 1 wiring. Surface mount units shall be used only in this manner for Canadian approval.

For direct ceiling mount, proceed as follows:

1. The knockouts are located on the side of the surface mount adaptor. Remove appropriate knockouts and install rubber grommets.
2. Mount adaptor to solid ceiling surface through slotted hole in adaptor mounting brackets. Supplied insulator gasket should be placed between ceiling and adaptor. Adaptor may be rotated to position detector.
3. Run system wiring through rubber grommets and connect to terminals on detector per Figure 3 observing applicable electrical codes.
4. Mount detector to adaptor with two #8-32 screws supplied.

For optional outlet box mount, proceed as follows:

1. Bend the mounting brackets on the supplied adaptor to fit standard 4-inch outlet box.
2. Mount adaptor to outlet box through slotted holes in adaptor mounting brackets. Adaptor may be rotated to position detector.
3. Connect system wiring to terminals on detector per Figure 3 observing applicable electrical codes.
4. Mount detector to adaptor with two #8-32 screws supplied.

**Figure 2: Flush Mount Units
(Series 27020-0 and 27021-0)**

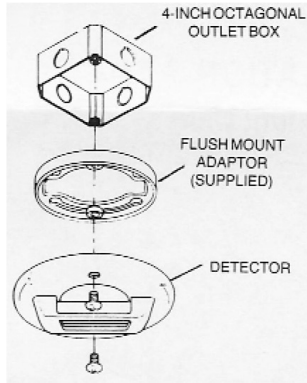

1. It is recommended that a standard 4-inch outlet box be used to mount the detector. Care should be taken that a neat 4-inch diameter hole be cut in ceiling to allow mounting clearance for detector. An oversized or ragged hole may show around the mounted unit.
2. Attach supplied flush mount adaptor to outlet box. Adaptor may be rotated in screw slots to position detectors as desired.
3. Connect system wiring to terminals on detector per Figure 3 observing applicable electrical codes.
4. Mount detector to adaptor with two #8-32 screws supplied.

Figure 3: System Wiring

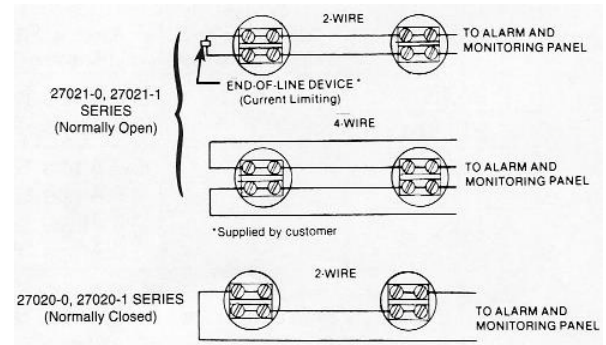

1. **In order to function properly, the sensing shell of the unit must remain free from paint, grease, oil, etc. Should such a build up occur, DO NOT, under any circumstances, attempt to remove it. Replace the unit.**
2. **Detectors mounted in an area subject to physical abuse or damage, other than above, must be suitable protected without obstruction the thermal airpath to the unit.**
3. **Do not install the unit where the shell would be physically damaged by sand, grain, rocks, etc.**
4. **Any detector that has been involved in a fire, abused or damaged must be replaced.**
5. **Consult the factory for special precautions necessary for outdoor use or moist environments.**



ANY OF THE ABOVE COULD CHANGE THE FACTORY TEMPERATURE SETTING, WHICH MAY RESULT IN PROPERTY DAMAGE AND/OR PERSONAL INJURY OR DEATH.

IT IS POSSIBLE FOR A UNIT TO HAVE BEEN ABUSED OR DAMAGED AND NOT DISPLAY ANY OUTWARD INDICATION OF THE DAMAGE. ALL UNITS SHOULD BE TESTED PERIODICALLY IN ACCORDANCE WITH NATIONAL FIRE PROTECTION ASSOCIATION REQUIREMENTS (72e) OR THE AGENCY HAVING LOCAL JURISDICTION.