

AMC2 - Access Modular Controller

www.boschsecurity.com

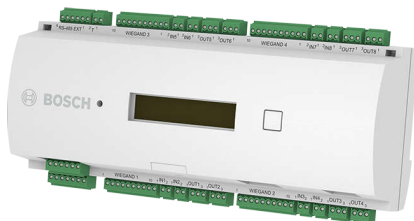

BOSCH
Invented for life



- ▶ Intelligent access manager for one to eight entrances
- ▶ Four interfaces include the reader power supply
- ▶ Standard 2 GB compact flash
- ▶ LCD display for displaying information
- ▶ Individual electronic verification of plugs and outputs

The AMC2 (Access Modular Controller) is used as an access controller in the access control systems ACE (ACCESS ENGINE) from version 2.0 onward, Access Personal Edition, and Access Professional Edition. The device controls a group of one to eight access points. These access points, also known as entrances, mainly consist of doors, gates, barriers, turn stiles, revolving doors, mantraps, ID card readers, door opening elements and sensors. The AMC2 can control up to eight ID card readers (depending on the reader type) and is designed for fully processing the access logic at the assigned entrances.

Status checks can be carried out using the eight analog inputs. The eight relay outputs are used to activate the door opening elements and/or generate the security activation and signaling. The AMC2 stores all necessary information in a battery-buffered memory and a compact flash storage element so that, even when the unit is offline, it is able to carry out independent authorization checks on access points, take access decisions, control closing/opening elements and register movement events.

System overview

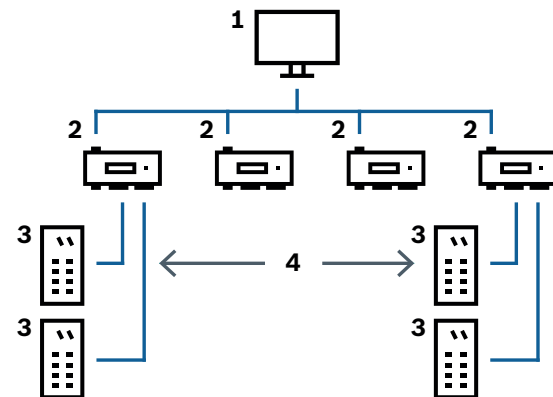

1 = Host computer

2 = AMC2

3 = Card reader

4 = Communication and power supply

As shown in the diagram, the AMC2 is integrated between the host system (e.g. Access Engine) and the peripheral devices.

The AMC2 is connected to the host system via RS485, RS232 (e.g. modem operation) or Ethernet, depending on the size of the system. The relevant host interface is selected during installation. The communication between the AMC2 and the host computer is encrypted with AES 128. All three interfaces are

available on the device by default. With RS485 operation, a maximum of eight AMC2s can be connected to one party line. There are up to four slots on the peripheral bus for readers.

Functions

- Storing downloaded data as listed below:
 - Master data
 - Authorizations
 - Access models
 - Display texts
 - Reader configurations
- Interpretation of transaction data from reader:
 - Authorization check
 - Host request
 - PIN code
- Control/monitoring:
 - Denial or door release
 - Switching alarm
 - Door statuses
 - Reader operation statuses
 - Internal alarm statuses
- Messages to Access Engine:
 - Host requests
 - Transaction data for storing
 - Error and malfunction messages
 - Alarm messages
- Power supply for:
 - Readers
 - Door openers
 - Contact current feeds

Certifications and approvals

Region	Regulatory compliance/quality marks	
Germany	VdS	G110090 G110090_AMC2-Schalteinrichtung
Europe	CE	EC-Declaration of Conformity
	EN5013 1	2101498_0551-QUA EMC IEC 60950-1 Safety general
	EN5013 1	2101498.0552-QUAIEMC EMC Directive 2004/108/EC
	EN5013 1	EN60950 210440750 IEC 60950-1 Safety General
Poland	CNBOP	0902 PL_CNBOP 0902
	CNBOP	0903 PL_CNBOP 0903

Installation/configuration notes

Power supply

An external power supply (10 to 30 V DC) for the AMC2 is connected to the pin 1 (positive) and 3 (negative). When using an uninterruptible power supply (UPS), the relevant UPS output relay can be connected to the pins:

- 4 and 7 for AC.
- 5 and 7 for battery.
- 6 and 7 for DC.

Otherwise, these pins will short-circuit.

Host connections

RS232 host interfaces

The Access Engine application administers up to 32 serial direct connections (ports). 1 AMC2 can be connected to each port, or 8 AMC2 to each ComPort.



Notice

Since PCs only have a maximum of two COM interfaces by default, the following connection variants are preferable for configurations with more than two AMC2's:

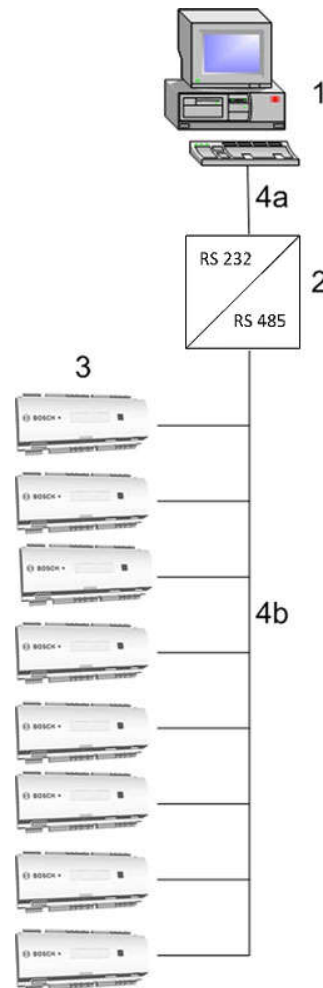

- 1 = Host computer
- 2 = RS232/485 converter
- 3 = AMC2
- 4a = RS232 connection
- 4b = RS485 connection: Up to eight AMC2's can be connected to one RS485 interface for each converter. The interface converter should be used if more than two AMC2's are connected. The interface converter generates an RS485 bus (2 or 4-wire) from a COM port and thus allows up to eight AMC2's to be connected with the RS485-typical distances (1200 m/3900 ft.).

Alternatively, the RS485 host interface (2 or 4-wire) can be activated in the AMC2 via a jumper. There are two sets of connection points; one for the incoming and one for the outgoing bus system.

Quantity restrictions

- Please follow the Access Engine installation and configuration instructions regarding the maximum number of access controllers on one access control system and the number of cards.
- Max. 4 access points/entrances.
- Max. 4 ID card readers.
- Max. 3 peripheral devices via internal RS485 bus.
- Max. 200,000 cards.

ID card reader connections

Wiegand interfaces

The AMC2 4W has four connections for connecting up to four ID card readers.

ID card reader and door control element interfaces are split into four channels, each with four connection plugs.

The following definitions apply to the Wiegand interface:

- 10-wire interface (incl. shield).
- Maximum cable length of 158 m (500 ft.) to ID card reader.
- 26-bit Wiegand format.
- 37-bit Wiegand format.

Default configuration of the Wiegand interface on the ID card reader:

1	12V+ reader power supply
2	12V- reader power supply
3	Data line 0
4	Data line 1
5	Shield
6	Green LED
7	Red LED
8	Acoustic signal
9	Delay
10	Show card

RS485 interfaces

The AMC2 4R4 has four connections for connecting up to eight ID card readers. The interfaces are divided to two busses - all possible readers (up to eight) can be connected to one interface.

RS485 interface definition:

- 2-wire interface: Using the 10-pin pluggable connector.
- Max. length of the bus: 1200 m.
- Transfer rates: 9,6 or 19,2 kBit/s.

Default configuration of the Rs485 interface on the ID card reader:

1	12V+ reader power supply
2	12V- reader power supply
3	Shield
4	Data RxTx+
5	Data RxTx-
6	Data shield (PAG)
7	Not connected
8	Not connected
9	Not connected
10	Not connected

Reader and door models

The AMC2 controls the connected reader via predefined door models.

Door models govern in accordance with the relevant security requirements

- Number and usage of the readers connected to the AMC2, e.g. input and output readers, input readers and buttons etc.
- Number and application type of the AMC inputs, e.g. door status, output button, revolving door position, GMA etc.
- Number and usage of AMC outputs, e.g. door opener, mantrap contact, signal light switching etc.

The maximum number of entrances to be managed by one AMC2 is ultimately defined by the door models used and their requirements regarding readers and inputs/outputs.



Notice

Therefore, when planning an access system, you must first assign the relevant door models to all entrances that are to be controlled. Only then can you configure the AMC reader.

Voltage equalization - grounding

- Different voltages can be equalized using jumpers with protective ground.
- A line (shield, equipotential bonding line) with protective ground can only be connected in one position.
- For further instructions, please see the operating manual.

Contacts

Inputs

The eight analog inputs can be used as digital or analog contacts. For analog use, resistance values can be specified that make it possible to carry out a further check for cable breaks and short-circuits.

Relay outputs

The relay outputs offer the following functions:

- The outputs can operate with potential free contacts for external power supply (dry mode).

- The outputs can operate using the internal voltage of power supply (wet mode).
- Only ohm resistive loads can be connected to the relay.
- Inductive loads must be bypassed via recovery diodes. These diodes (1N4004) are enclosed.

General instructions

- AMC2 and related equipment should be mounted in a "secured area".
- Detailed connection conditions are specified in the operating manual.
- After purchase, primary AC power must be carried out by a licensed electrician.

Technical specifications

Hardware	CPU RENESAS M32C84 Integrated Microcontroller (32Bit, 30MHz)
	512 kB-EPROM/FLASH
	256 kB-SRAM
	Serial EEPROM
	RTC
	Pluggable 2 GB compact flash
	Battery for SRAM and RTC
	Host address can be set via sliding switch
	Host interface: - RS485 (2- or 4-wire); opto-decoupled - RS232 - Ethernet 10/100BaseT (TCP/IP) with RJ45
	4 reader interfaces: - Wiegand or - RS-485, 2-wire, opto-coupled, 19.200 Bd
	8 relay outputs: - max. switching voltage: 30 V DC - max. switching current: 1,25 A
	8 monitored analog inputs
	Tamper switch
	Reset button
Temperature	0°C to +50°C (32°F to 122°F)
Power supply	10 to 30 VDC, max. 60 VA Available for external devices: 55 VA
Environment class	IP 30
Housing	Base: PPO (UL 94 V-0) Upper: Polycarbonate (UL 94 V-0)
Color	White
Dimensions	WxHxD: 232 x 90 x 63 mm (9.13 x 3.54 x 2.48 in.)

Weight	Approx. 0.53 kg (1.17 lb)
Type	Rail mounting

Ordering information

APC-AMC2-2WCF Door controller WI, 2 readers

Two Wiegand interfaces for up to 2 card readers, network connection to the host system and Compact Flash memory (2 GB). Host data transfer encrypted. Order number **APC-AMC2-2WCF**

ACX-RAIL-400 DIN rail 400mm

Mounting rail (400 mm) for mounting the AMC-4W, AMC PS-12V-60W and AMC UPS-12V when the metal housing AMC ENC-V1 is not used. Order number **ACX-RAIL-400**

APS-PSU-60 Power supply unit

A power supply unit with an integrated battery charging device, that supports 12 V/7 Ah, 12 V/14 Ah and 24 V/7 Ah batteries, with selectable 12 VDC or 24 VDC voltage output. Order number **APS-PSU-60**

D126 Battery, 12V 7Ah

A rechargeable sealed lead-acid power supply used as a secondary power supply or in auxiliary or ancillary functions. Order number **D126**

APC-AMC2-4WCF Door controller Wiegand with CF card

MANDATORY*
Four Wiegand interfaces for up to 4 card readers, network connection to the host system and Compact Flash memory (2 GB). Host data transfer encrypted. Order number **APC-AMC2-4WCF**

EWE-AMCCTR-IW 12mths wrty ext. AMC Reader Controller

12 months warranty extension
Order number **EWE-AMCCTR-IW**

APC-AMC2-4R4CF Door controller RS485 with CF card

MANDATORY*
Four RS-485 interfaces for up to 8 card readers, network connection to the host system and Compact Flash memory (2 GB). Host data transfer encrypted. Reader data transfer encrypted according to reader capabilities. Order number **APC-AMC2-4R4CF**

EWE-AMCCTR-IW 12mths wrty ext. AMC Reader Controller

12 months warranty extension
Order number **EWE-AMCCTR-IW**

Accessories**API-AMC2-4WE Door controller Wiegand extension**
MANDATORY*

The extension module AMC2 4W-EXT is equipped with four Wiegand type reader-interfaces plus eight inputs and eight outputs. Hence with the AMC2 4W-EXT it is possible to double the number of readers on an AMC2 4W from 4 to 8.

Order number **API-AMC2-4WE**

API-AMC2-8IOE Extension board with 8-input 8-output
MANDATORY*

8 input/output extension board, up to three per AMC, can be combined with the AMC2 16I-EXT and the AMC2 16I-16O-EXT.

Order number **API-AMC2-8IOE**

API-AMC2-16IOE Extension board with 16-input 16-output

16 input/output extension board, up to three per AMC, can be combined with the AMC2 16I-EXT and the AMC2 8I-8O-EXT.

Order number **API-AMC2-16IOE**

API-AMC2-16IE Extension board with 16-input
MANDATORY*

16 input extension board, up to three per AMC, can be combined with the AMC2 16I-16O-EXT and the AMC2 8I-8O-EXT.

Order number **API-AMC2-16IE**

API-AMC2-16ION Standalone controller for BIS with OPC

MANDATORY*

Standalone controller with inputs and outputs only. Compatible with BIS in combination with OPC Server only.

Order number **API-AMC2-16ION**

AEC-AMC2-UL01 AMC enclosure with 1 DIN rail

Compliant with UL294 system certification for AMC2. Order number **AEC-AMC2-UL01**

AEC-AMC2-UL02 AMC enclosure with 2 DIN rails

Compliant with UL294 system certification for AMC2. Order number **AEC-AMC2-UL02**

AEC-AMC2-EMEA01 AMC enclosure DE type

This enclosure is used for securely mounting and housing the AMC2 and a power supply (e.g. AMC PBC60).

Order number **AEC-AMC2-EMEA01**

AEC-PANEL19-UPS Fitting panel, 19", 2 DIN rails

Mounting plate with two DIN rails, a battery bracket, and screw sockets for the power supply to mount into 19" racks.

Order number **AEC-PANEL19-UPS**

AEC-PANEL19-4DR Fitting panel, 19", 4 DIN rails

Mounting plate with four DIN rails for 19" racks to connect max. four AMC2 devices.

Order number **AEC-PANEL19-4DR**

APS-PSU-60 Power supply unit

A power supply unit with an integrated battery charging device, that supports 12 V/7 Ah, 12 V/14 Ah and 24 V/7 Ah batteries, with selectable 12 VDC or 24 VDC voltage output.

Order number **APS-PSU-60**

Gel Battery 12 V / 7.2 Ah

(DU = 1 unit)

Order number **IPP-12V-7.2Ah**

Battery CR 2032

Lithium Manganese Dioxide battery

Order number **Battery CR 2032**

Represented by:

Europe, Middle East, Africa:
Bosch Security Systems B.V.
P.O. Box 80002
5600 JB Eindhoven, The Netherlands
Phone: + 31 40 2577 284
emea.securitysystems@bosch.com
emea.boschsecurity.com

Germany:
Bosch Sicherheitssysteme GmbH
Robert-Bosch-Ring 5
85630 Grasbrunn
Germany
www.boschsecurity.com

North America:
Bosch Security Systems, LLC
130 Perinton Parkway
Fairport, New York, 14450, USA
Phone: +1 800 289 0096
Fax: +1 585 223 9180
onlinehelp@us.bosch.com
www.boschsecurity.us

Asia-Pacific:
Robert Bosch (SEA) Pte Ltd, Security Systems
11 Bishan Street 21
Singapore 573943
Phone: +65 6571 2808
Fax: +65 6571 2699
apr.securitysystems@bosch.com
www.boschsecurity.asia