

N·E·A·R®

Orbit Ceiling Speaker

Model OCS1



Description

The Orbit Ceiling Speaker (OCS1) is the ideal choice for various types of ceiling environments.

The OCS1 features NEAR's MLS™ and MDT™ technologies (see below), which improve sound quality and increase operating reliability.

The low-distortion speaker design, featuring NEAR's spiderless driver and one-piece metal-alloy cone structure, delivers superb articulation and the highest intelligibility for both music and speech.

The speaker can be easily installed on hard surfaced ceilings, or in suspended ceilings and new construction (with the optional TBCR bracket).

MDT™ (Metal Diaphragm Technology)

- Solid, one-piece cone structure eliminates the traditional dust cap
- Extremely stable cone structure over long periods of time
- Fast transmission of sound through the diaphragm means low energy storage
- Special hard anodizing process creates a ceramic surface for increased stiffness
- Super-efficient thermal path for cooling the voice coil (not paper or plastic)
- High rigidity and low mass of metal versus typical paper or plastic cones

MLS™ (Magnetic Liquid Suspension)

- Magnetic liquid (Ferrofluid) injected into magnet gap
- Elimination of the conventional cloth centering spider
- Constant lubrication of the gap prevents oxidation from occurring
- Voice coil is most efficiently cooled by fluid path rather than air
- Lower distortion via stronger centering forces on voice coil
- Increased reliability, particularly in high power daily use systems

Features

- Wide-dispersion coaxial driver for broad, even 140° coverage
- Stable, high definition metal-alloy cone
- MDT™ cone design delivers detailed sound
- MLS™ eliminates conventional centering “spider” for more accurate voice coil centering
- High-efficiency drivers deliver superior performance
- Extremely good off-axis response
- Computer-matched venting system for full bass output
- High power handling capability for foreground sound
- Selectable power taps via front-mounted control
- 16-ohm input for non-transformer multi-speaker systems
- Easy wiring with snap-on connector
- Connector provides loop-through to next speaker
- Attachment point for seismic cable (safety cable)
- Input terminal cover with knockouts and safety eyelet provides protection for connections
- Low-resonance cabinet structure
- Off-white textured finish; easily painted to match theme decors
- Listed to UL Standard 60065 for US and Canada
- Independently tested and meets requirements of UL-2043 (report available)
- Attractive, contemporary, sturdy steel grille assembly with fine perforation(s)
- Accessory tile bridge support ring (Model TBCR sold separately)
- Accessory 10-foot long cable kit (Model CK10 sold separately)

Technical Specifications

SPECIFICATIONS	OCS1
Frequency Response (-10 dB)*	45 Hz to 19 kHz
LF Driver	6-1/2" MDT Metal-Alloy Cone (MLS Voice Coil Centering System)
HF Driver	20 mm (3/4") Polycarbonate Dome
Sensitivity (1W/1m)	89.5 dBspl
Usable Coverage Area	140°
Impedance Ratings	Low (16 ohms) / High (70V/100V)
Power Input (Max.)	100W @ 16 ohms; 32W @ 70V/100V
Power Settings (in watts)†	70V: 32, 16, 8, 4, 2, 1W & 16 ohms 100V: 32, 16, 8, 4, 2W & 16 ohms
Baffle Material	Fire-rated (94VO) ABS
Back Can Material	Heavy-Gauge Plated Steel
Terminations	4 Terminal Snap-Lock Input Connector
Product Weight	10 lb.
Speaker Dimensions	12-3/8" dia. x 12" D
Vertical Clearance Requirement	Minimum 11" (From front of Mounting Surface)
Included Accessories	Input Terminal Cover (2 Halves); (4) Screws; (1) Snap-Lock Input Connector
Optional Accessories	Tile Bridge Support Ring (TBCR)
Baffle Ring Finish & Color	Textured Off-white
Listings	Listed to UL Standard 60065 for US & Canada; UL-2043

* Half-Space Response, 16-ohm input

† Front panel, switch-selected (under grille)

Architect & Engineer Specifications

The loudspeaker shall be a NEAR Orbit Model OCS1 Ceiling Speaker or approved equivalent, consisting of one 6-1/2" (nominal) low frequency transducer, one 20mm (3/4") (nominal) high frequency transducer with a filter network for dividing frequencies between the transducers.

The front baffle shall be injection-molded, ABS material containing fire inhibitors with a 94VO rating, and the back can (enclosure) shall be plated steel. All components shall be mounted inside the enclosure.

The baffle shall be supplied in off-white with a mild texture finish to promote paint adhesion if desired. A perforated speaker grille shall be made from heavy-gauge steel, color-matched to the baffle.

The low-frequency driver shall utilize a metal-alloy cone with hard-anodized surface treatment for rigidity and corrosion resistance. The cone shall provide a heat transfer element for the voice coil under high-power input. A compounded rubber cone surround shall be formulated to withstand environmental conditions with high or low heat, high or low humidity, and ultra-violet light. The voice coil shall be protected via a high gauss low viscosity magnetic liquid (ferrofluid), to prevent corrosion from occurring in the magnet gap. The fluid will also serve as a thermal path to further reduce heat build-up in the voice coil. The driver will utilize the ferrofluid to provide a centering force for the voice coil in the magnet gap.

The high-frequency driver shall utilize a diaphragm consisting of black polycarbonate. Ferrofluid shall dampen the voice coil and facilitate the transfer of heat from the coil to the magnet structure.

Integral swing-out clamps shall provide a secure installation in the ceiling surface. A safety cable attachment point shall be included in the removable terminal cover enclosure. An optional 10-foot long cable kit shall be available to serve as a back-up support cable (Model CK10). An optional tile bridge support ring installation bracket shall provide additional support when mounting the loudspeaker into suspended ceilings (Model TBCR). The bracket shall also serve as a pre-installation guide for new construction installations, providing attachment to either 16" OC or 24" OC mounting.

The input connector shall be a 4-screw snap-lock input connector, providing "loop-through" for additional speakers.

Power input selection shall be via a front-mounted rotary switch, located under the removable grille. 70V (high-impedance) tap selections shall be 1, 2, 4, 8, 16, and 32 watts; 100V (high-impedance) tap selections shall be 2, 4, 8, 16, and 32 watts. A low-impedance 16-ohm selection shall also be provided. Usable coverage area shall be 140°.

Dimensions of the speaker shall not exceed 12-3/8" dia. x 12" D. Product weight shall be 10 lb.

Frequency Response

Half-space @ 1m

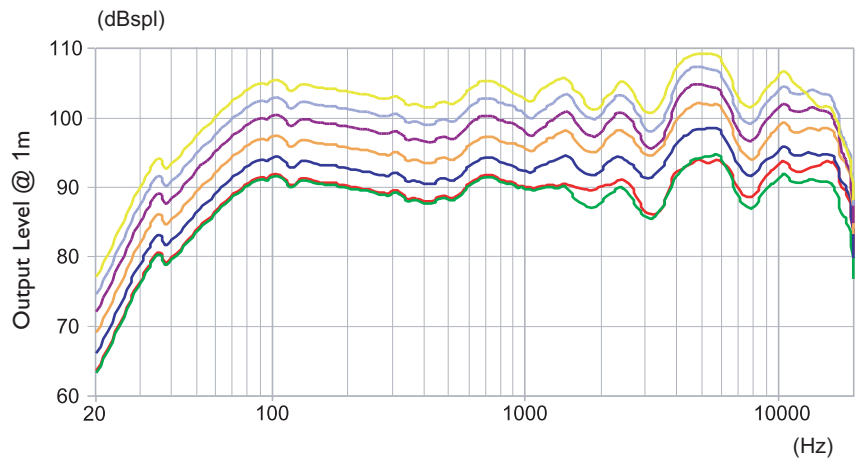

Off-Axis Response

Graph shows modification to an on-axis response.

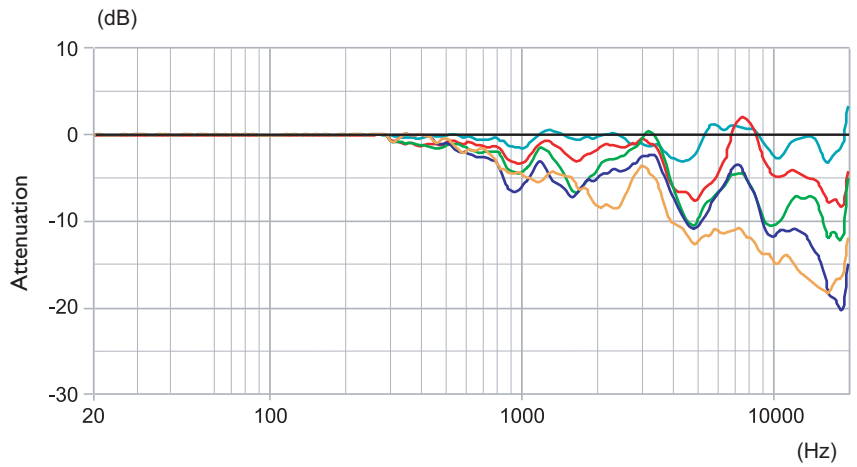
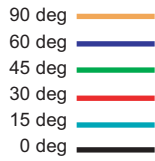

Polar Response

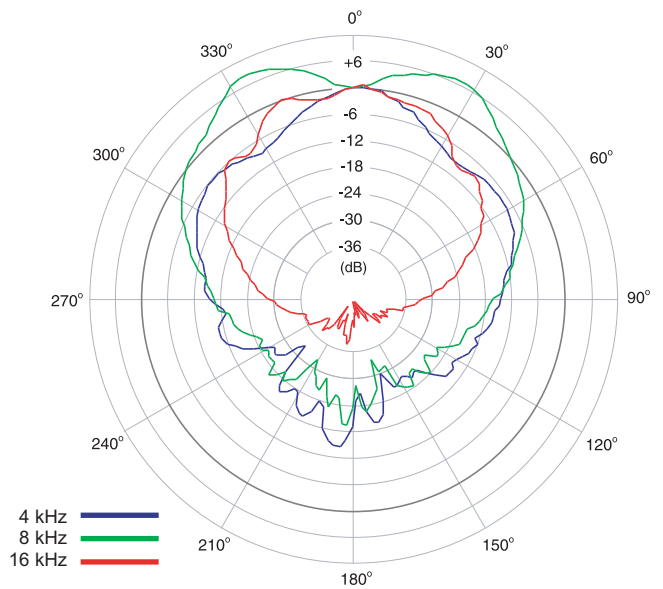
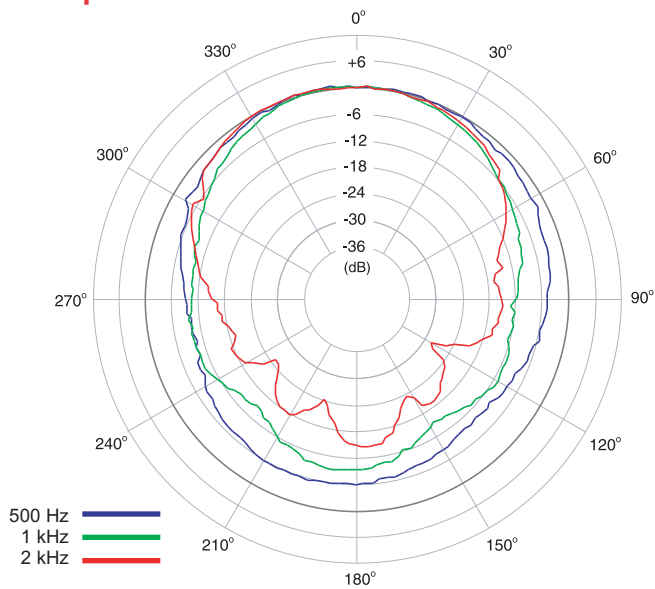

Mechanical Drawings

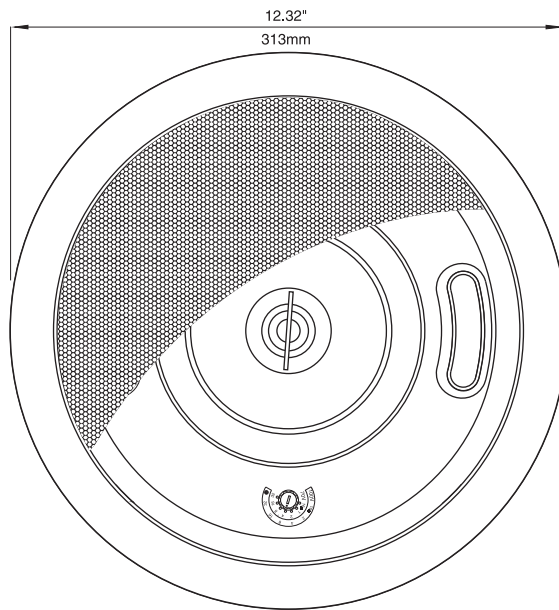

(Grille shown partially removed)

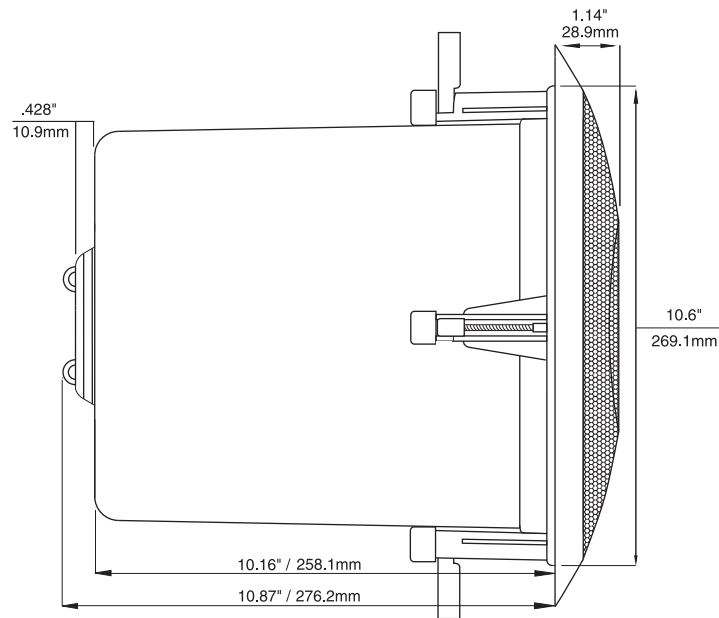

BOGEN[®]
COMMUNICATIONS, INC.

50 Spring Street, Ramsey, NJ 07446, USA

Tel: 201-934-8500 • Fax: 201-934-9832

www.bogen.com