

# L-PCP20A

## 5" ABS COAXIAL CEILING LOUDSPEAKER WITH ABS DOME

- Coaxial design provides wider frequency range
- Adjustable 70V and 100V inputs
- Easy connection and installation
- Sturdy ABS grille for reliable electrical insulation and longer operating life
- CE and RoHS complied

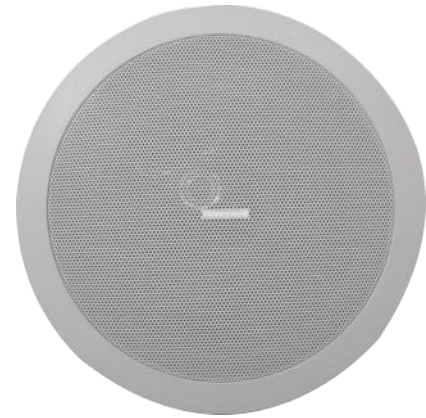

### PRODUCT DESCRIPTION

L-PCP20A is a powerful ceiling mounted loudspeaker. The full range loudspeaker features a strong ABS enclosure finished in elegant and low-profile white. It is specially designed for environments such as shops, supermarkets, educational institutes, offices, sports fields, hotels and restaurants, which require excellent speech and acoustic performance. The coaxial design enhances a wider frequency response range and

thus the acoustic performance. The rubber-made bass gasket cone guarantees good linearity when the unit is in large dynamic range of low frequency. The treble effect utilizes a thin Mylar material which extends the frequency up to 20kHz. The clamp-on terminal provides ease of wire connection. The loudspeaker is CE and RoHS complied.

#### Technical Specification

Max power	30 W
Rated power	20 W
Power taps @ 100V	20 W / 10 W
Power taps @ 70V	10 W / 5 W
SPL at 20W / 1W(150Hz-20k Hz, 1m )	102 dB / 90 dB
Frequency response(-10dB)	100 Hz - 20 KHz
Dispersion angle 1k Hz / -6 dB)	120 °
Rated impedance	500 Ω / 1K Ω
Connector	Binding post terminals

Rated input voltage	100 V / 70 V
Dimensions(Φ×H)	Φ 240 mm × 151 mm
Hole cut-out size	Φ 2 10 mm
Diameter of speaker	5.5"
Weight	2.0 Kg
Color	White ( RAL9010 )
Weight of magnet	283 g

## Frequency Response

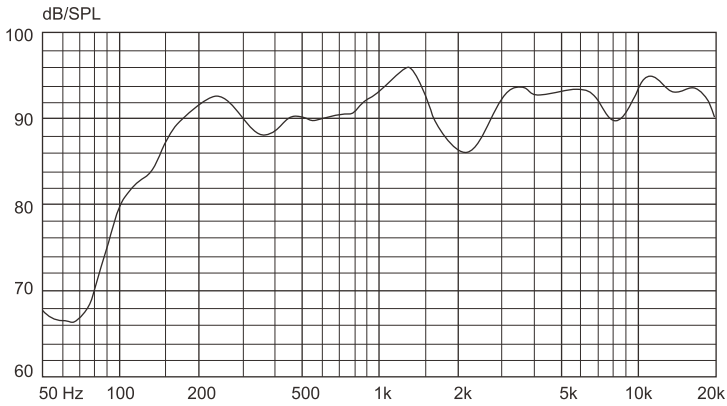

## Circuit Diagram

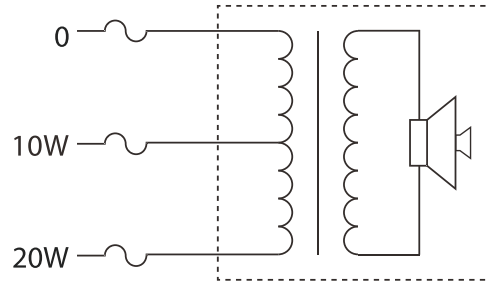

## Polar Diagram

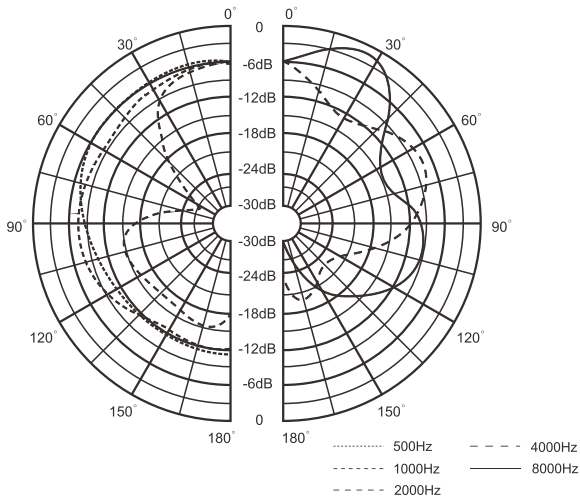

## Three-View Diagram

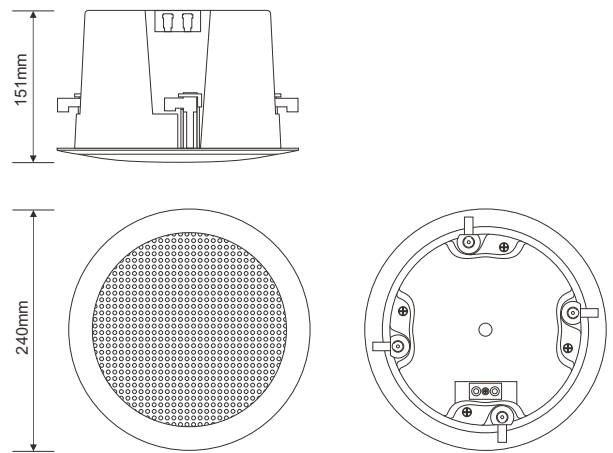

For more information,  
<https://honeywellbuildings.in>  
 Call: 1-800-103-0339  
 Email: HBT-Indiabuildings@honeywell.com

**Honeywell HBT India Buildings**  
 Unitech Trade Center, 5th Floor, Sector-43,  
 Block C, Sushant Lok Phase - I,  
 Gurgaon - 122 002

[www.honeywell.com](http://www.honeywell.com)

© 2020 Honeywell International Inc.

**L-PCP20A**  
**5" ABS COAXIAL**  
**CEILING LOUDSPEAKER**  
**WITH ABS DOME**

**Honeywell**