

## UHF Synthesized Wireless Microphone System

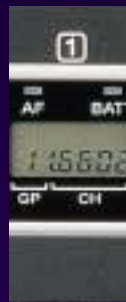

---

# Superb performance and reliability in an affordable package



*Since its introduction, the unique qualities of the Sony UHF synthesized wireless microphone system have been proven in many different applications. It has been particularly successful in broadcasting and production, where its low noise, wide audio dynamic range, stable RF transmission and reception, and high reliability are critical.*

*In recent years, Sony has enhanced its wireless microphone line-up to fulfill the ever-increasing needs for wireless operations. Offering a broad range of choices, this family presents a solution to virtually any wireless microphone application from the very simple to the most sophisticated. Such applications include ENG and EFP location, conference and entertainment, TV studio production, theater, and live performance to name just a few. A variety of options are also made available so that systems are established to suit different operational needs.*

*The Sony UHF synthesized wireless microphone system offers a perfect choice for all levels of operational and budgetary needs.*

## PLL Synthesized System

Phase Locked Loop (PLL) frequency synthesized systems are employed both in transmitters and receivers, providing both carrier stability and easy access to multiple frequencies. These PLL controlled systems provide highly stable, selectable frequencies to be generated in increments of 125 kHz. Users may choose from 94 frequencies on all A-series (USA type) models and from 188 frequencies on B-series (USA type) models.

## Space Diversity Reception System

A space diversity reception system is used to eliminate signal dropout. Dual antenna inputs and reception circuits incorporated in the diversity system receive signals over two different paths and select the stronger signal as the output. This switching operation is undetectable on the audio output of the receivers.

## Pre-programmed Frequency Groups

Optimum combinations of calculated and practically tested intermodulation-free frequencies are stored in the CPU of each receiver to make it easy to choose the correct frequencies for simultaneous multi-channel operation. These frequencies are arranged in groups, with each group pre-programmed to allow inter-modulation free operation.

## Advanced Filtering

The Sony wireless units all employ Helical, Ceramic and/or SAW (Surface Acoustic Wave) filters as appropriate. This offers stable reception and excellent audio quality, and also enables the unique miniaturization seen in most of the Sony products.

## Tone Squelch Circuitry

The wireless microphone transmitters also transmit a 32 kHz tone signal along with the program audio signal. In the receivers, a squelch circuit is present, and the program signal is only output when the tone signal has been correctly received.

This squelch feature is designed to eliminate undesired signals and noise from other equipment and eliminates RF noise and popping when the transmitter is powered off.

## Componder System for Wide Dynamic Range and Low Noise

A compander (compressor/expander) system is included for improved audio dynamic range and low noise and interference. The time constants for attack and release times are carefully chosen in the various transmitters to match the application, providing minimized noise levels while providing smooth and excellent audio quality.

## Multiple Information on Easy-to-read LCD and LED

Most receivers and transmitters feature a built-in, easy-to-read LCD, which provides extensive status information. All receivers will display the diversity RF and AF signal strength, frequency and channel groups chosen, and battery status of the transmitter.

Most transmitters do in essence have the same information available in the display; such as AF input level, and RF output, battery status, current channel number, selected frequency, input attenuation setting, and accumulated battery operating time.

## Remote Battery Alarm on Receiver

For added assurance of continued operation, you can monitor the battery reserves of handheld, body pack and plug-on transmitters. Remaining battery life is indicated on both the transmitter and receiver, with an additional indication approximately one hour\* before the battery goes dead. On the receiver, the battery indicator on the LCD and LED displays also flash, helping to avoid the chance of battery failure at a critical moment.

\*This may vary depending on the operational environment.

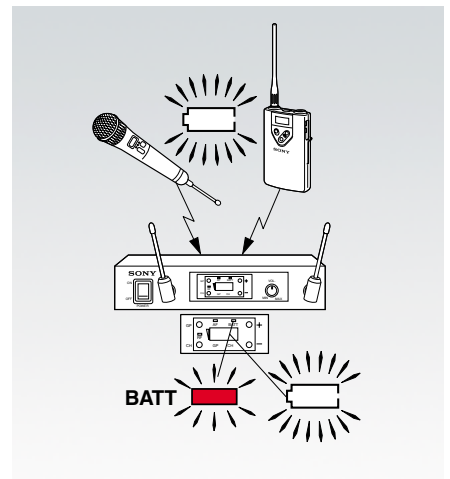

## Consistent RF power output

A DC-DC convert circuit built into the power supply section of microphones/transmitters provides consistent output power over the life of the batteries.

## Channel Setting Back-Up

Each unit has a convenient memory back-up for storing operating frequencies. When the power switch is turned on, the previous channel setting is automatically recalled and displayed.

## Live Music Production

### 22-channel simultaneous operation

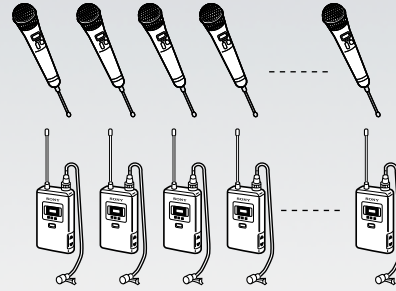
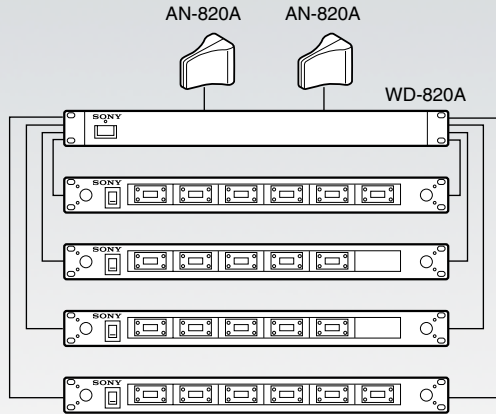

#### Required components

- MB-806A Tuner base unit x 4
- WRU-806B Tuner unit x 22
- AN-820A Antenna x 2
- WD-820A Antenna divider x 1
- Transmitter x 22

\* Lavalier microphones are not supplied with transmitters.  
22-channel simultaneous operation is possible by combined use of WRU modules on both 62/64 and 66/68. The WD-820A (USA type) operates over the entire range of TV channels 62-69.

## Theaters

### 36-channel simultaneous operation

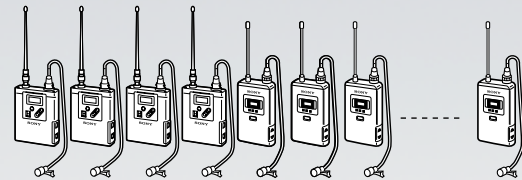
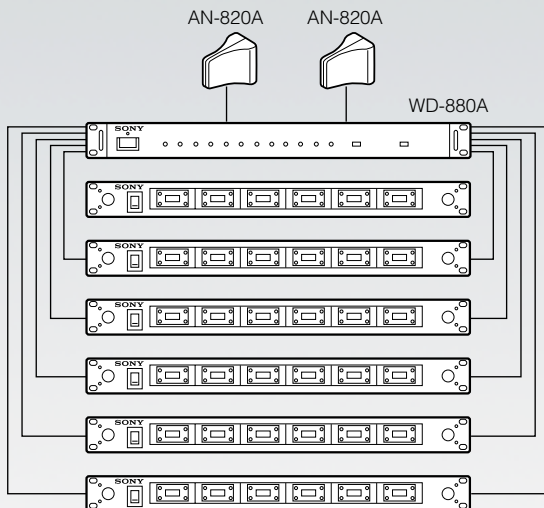

#### Required components

- MB-806A Tuner base unit x 6
- WRU-806 Tuner unit x 36
- AN-820A Antenna x 2
- WD-880A Antenna divider x 1
- Transmitter x 36

Note) WD-880A (USA type) operates on TV channels 64-69

Note) The above systems can be configured when using USA-type models.

Max. 42-channel simultaneous operation is possible by using additional antenna dividers, tuners and transmitters.

## Conference/Educational Applications

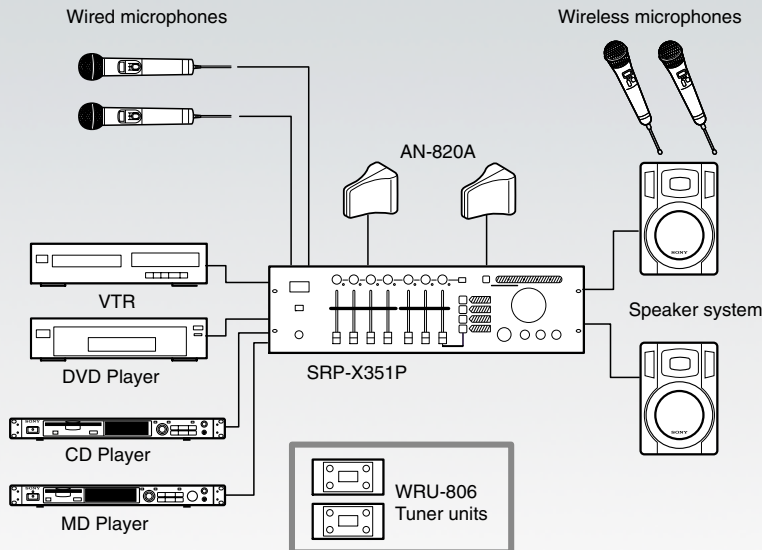

### Required components

- WRU-806 Tuner unit x 2
- Wireless Microphone x 2
- Wired Microphone x 2
- AN-820A Antenna x 2
- SRP-X351P Audio Mixer x 1

Mounting slots for two WRU-806 tuner units are built into the rear panel of SRP-X351P.

## ENG/FP Applications

### Betacam SX® camcorder with WRR-855

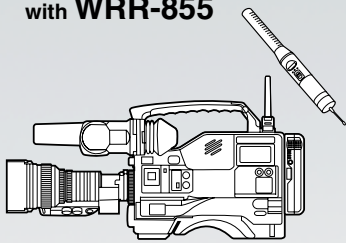

#### Required components

- WRR-855 Tuner x 1 (slot-in type)
- Transmitter x 1

WRR-855 works with all Betacam SX camcorders (drop-in configuration) models; DNW-7/7P, DNW-9WS/9WSP, DNW-90/90P, DNW-90WS/90WSP and DNV-5.

### Small camcorder\* with WRR-805

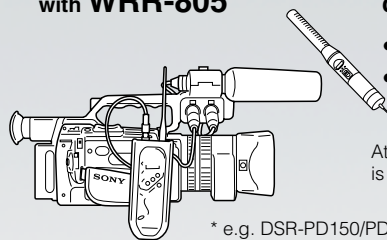

#### Required components

- WRR-805 Tuner x 1
- Transmitter x 1

Attachment case for WRR-805 is supplied with the tuner.

\* e.g. DSR-PD150/PD150P, DCR-VX2000

### DVCAM camcorder with WRR-855

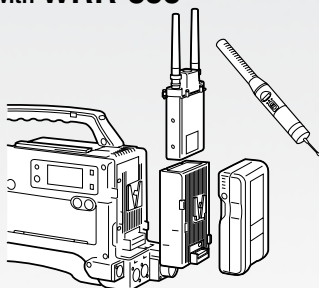

#### Required components

- WRR-855 Tuner x 1
- CA-WR855 Camera adapter x 1
- Transmitter x 1

### Digital Betacam® camcorder with WRR-862

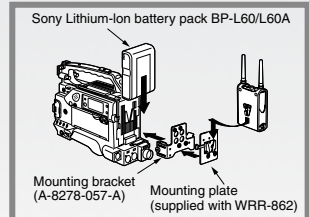
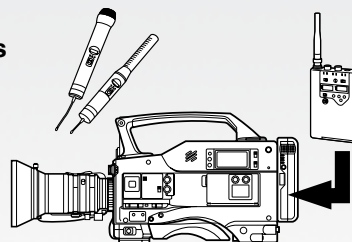

#### Required components

- WRR-862 Tuner x 1
- A-8278-057-A Mounting bracket\*
- Transmitter x 2

\* Available only through Sony parts

## Common Features

- PLL frequency synthesized circuitry for highly stable operation
- $1/4 \lambda$  whip antenna (except WRT-867A which uses a helical antenna)
- Transmits battery status to compatible receivers (except WRT-867A)
- Easy-to-read LCD screen and LED's indicates extensive information

Model name	Channel number	Channel frequency in MHz	AF condition	RF condition	Compander time constant	Attenuator	Battery status	Accumulated battery operating time
<b>WRT-847B</b>	LCD	LCD	LCD	LCD	LCD	LCD	LCD	LCD
<b>WRT-867A</b>	LCD	—	—	—	—	—	—	—
<b>WRT-807A</b>	LCD	LCD	LCD	LCD	—	LCD	LCD	LCD
<b>WRT-860A</b>	LCD	LCD	LCD	LCD	—	LCD	LCD	LCD
<b>WRT-822B</b>	LCD	LCD	LCD	LCD	—	LCD	LCD	LCD
<b>WRT-805B</b>	LCD	LCD	LCD	LCD	—	LCD	LCD	LCD
<b>WRT-808A</b>	—	—	LED	—	—	—	LED	—



## WRT-847B UHF Synthesized Transmitter Unit

- Five optional microphone capsules are available, providing a choice of characteristics that suit a range of different applications. Microphone capsules are available individually. (One head is required for the WRT-847B for function.)
- Audio compander time constant is switchable to suit different capsules
- Selectable RF output level: 10 mW for simultaneous multi-channel operation and 50 mW for long working distance
- Audio gain and attenuation setting from +9 dB to -12 dB in 3 dB steps
- Lockable external power switch (ON/OFF)
- Easy-to-read LCD with back light
- Two AA-size alkaline batteries provide approx. eight hours of continuous operation



## CU-F780 Capsule Unit

- Dynamic microphone with super cardioid polar pattern
- Uses the same high quality edgewise winding Copper Clad Aluminum Wire voice coil that is employed in the acclaimed Sony F-780 wired microphone
- Designed for vocal applications including live music performance
- Frequency response: 50 Hz to 18 kHz
- Dimensions:  $\varnothing$  51 x 90 mm  
( $\varnothing$  2 1/8 x 3 5/8 inches)
- Mass: 180 g (6.3 oz)

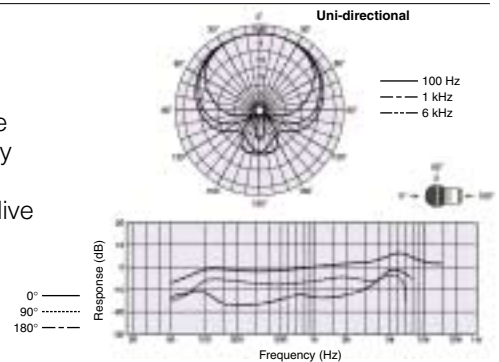



## CU-G780 Capsule Unit

- Dynamic microphone capsule with super cardioid polar pattern
- Special design, based on the capsule of the F-780 microphone, to cope with high sound pressure level vocals and incorporating outstanding feedback rejection
- Designed for vocal use
- Frequency response: 50 Hz to 20 kHz
- Dimensions:  $\varnothing$  51 x 90 mm  
( $\varnothing$  2 1/8 x 3 5/8 inches)
- Mass: 180 g (6.3 oz)

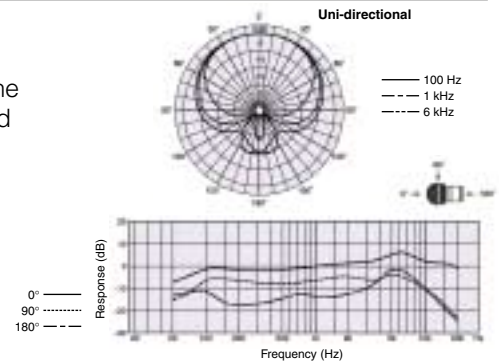

## CU-E700 Capsule Unit

- Electret condenser microphone capsule with super cardioid polar pattern
- Smooth frequency response for natural sound reproduction
- Suitable for critical vocal and speech applications
- Frequency response: 50 Hz to 18 kHz
- Max. SPL: 150 dB
- Dimensions:  $\varnothing$  51 x 98 mm  
( $\varnothing$  2 1/8 x 3 7/8 inches)
- Mass: 170 g (6.0 oz)

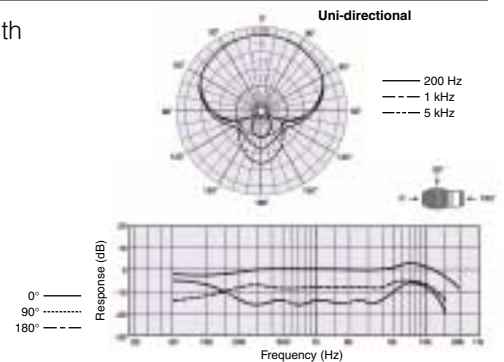

## CU-E672 Capsule Unit

- Electret condenser microphone capsule with hyper cardioid polar pattern
- A wide variety of applications in news-gathering, sports events and interviews
- The supplied screen reduces wind noise and popping
- Frequency response: 50 Hz to 16 kHz
- Max. SPL: 120 dB
- Dimensions:  $\varnothing$  37 x 172 mm  
( $\varnothing$  1 1/2 x 6 7/8 inches)
- Mass: 150 g (5.3 oz)
- Supplied accessory: Urethane wind screen (1)

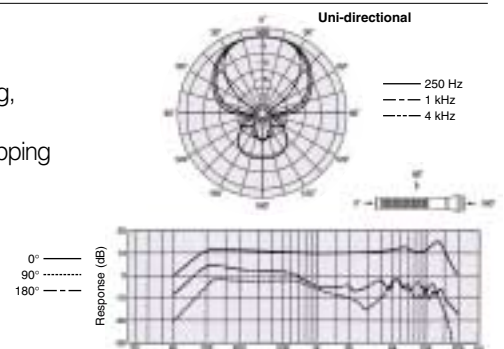

## CU-F117 Capsule Unit

- Dynamic microphone capsule with omni-directional polar pattern
- Excellent rejection of wind noise and popping
- Designed for interview applications
- Frequency response: 50 Hz to 15 kHz
- Dimensions:  $\varnothing$  44 x 105 mm  
( $\varnothing$  1 3/4 x 4 1/4 inches)
- Mass: 170 g (6.0 oz)
- Supplied accessory: Urethane wind screen (1)

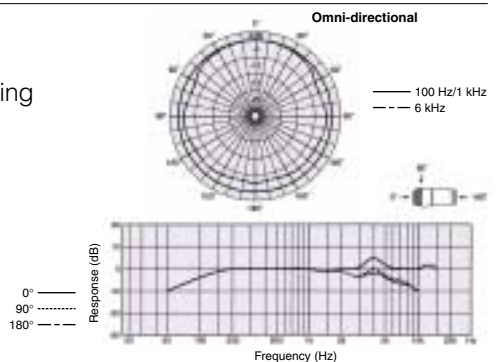



## WRT-867A/X UHF Synthesized Wireless Microphone

- Dynamic microphone capsule with super-cardioid polar pattern
- Resilient body structure for extremely high quality sound
- Incorporates a high quality, edgewise-winding voice coil with lightweight CCAW (Copper Clad Aluminum Wire) and AlNiCo magnet, which provides powerful, crisp and clear sound as well as presence in the middle and high frequency range
- Ideal for critical vocal applications for broadcast program and film production
- Channel select switches, audio attenuator switch and an LCD indicator inside the body to prevent mis-operation

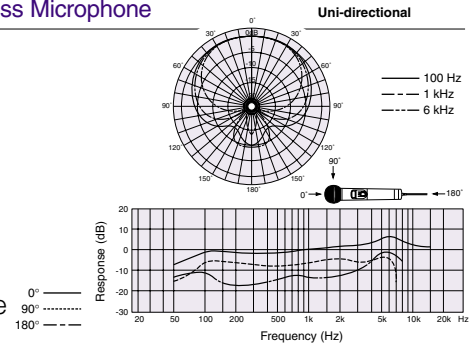

## WRT-807A UHF Synthesized Wireless Microphone

- Uses the same dynamic microphone capsule that is employed in the F-780 professional wired microphone
- High sound quality for vocals – powerful, crisp and clear sound
- One AA-size alkaline battery allows continuous operation for five hours
- 10 mW RF output
- Lockable external power switch (ON/OFF)

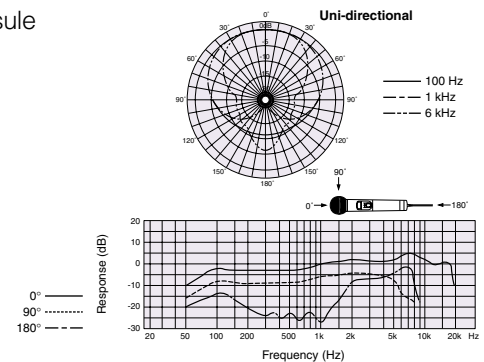

## WRT-800A68 UHF Synthesized Wireless Microphone

- Wide-cardioid electret condenser capsule
- Up to 12 hours of continuous operation with a single AA-sized (LR6) alkaline battery. RF power output: 5 mW
- Battery alarm transmitted to compatible receivers
- Ergonomic grip
- Low profile miniature helical antenna
- Easily detachable mic holder (supplied) for use on a stand



## WRT-808A UHF Synthesized Transmitter

- Plug-on transmitter—converts a wired microphone to a wireless microphone
- Fitted with an XLR connector
- Compact and lightweight body, providing balanced handling
- Durable connecting mechanism for dependable operation
- Variable (0 dB to 50 dB) input attenuation and selectable (10 mW or 50 mW) RF power output
- Audio input level (Reference and peak) indication by LED





### WRT-860A UHF Synthesized Transmitter

- Ultra-compact and lightweight design
- Stable 20 mW RF output and compander system for expanded operating distance
- Approximately six hours of continuous operation with two AA-size (LR6) alkaline batteries
- Accepts professional lavalier microphone fitted with SMC-4P connector
- SMA-J removable connector type antenna
- Selectable (0 dB to 30 dB in 3 dB steps) input attenuation



### WRT-822B UHF Synthesized Transmitter

- Approximately six hours of continuous operation with two AA-size alkaline batteries
- Compact, lightweight, magnesium alloy body
- 20 mW RF power output
- Accepts professional lavalier microphones fitted with SMC9-4P connector



### WRT-805B UHF Synthesized Transmitter

- One AA-size alkaline battery allows continuous operation for six hours
- Smoothly tapered body pack with compact and lightweight design
- Switchable (-40 dB/-60 dB) input level and PHASE switches for guitar and lavalier microphone
- 3.5 mm (5/32-inch) dia., 3-pole mini jack with a lock mechanism for secure lavalier cable clamping

## Model variations

	<b>WRT-8□□B62/64</b> 758 MHz to 782 MHz USA TV channels 62 to 65	<b>WRT-8□□B66/68</b> 782 MHz to 806 MHz USA TV channels 66 to 69		
<b>B series</b> (USA type)	WRT-847B (Handheld transmitter)	●	●	
	WRT-807B (Handheld microphone)	●	●	
	WRT-822B (Body pack transmitter)	●	●	
	WRT-805B (Body pack transmitter)	●	●	
	<b>WRT-8□□A64</b> 770 MHz to 782 MHz USA TV channels 64 to 65	<b>WRT-8□□A66</b> 782 MHz to 794 MHz USA TV channels 66 to 67	<b>WRT-8□□A68</b> 794 MHz to 806 MHz USA TV channels 68 to 69	
<b>A series</b> (USA type)	WRT-867A (Handheld microphone)	—	—	●
	WRT-860A (Body pack transmitter)	●	●	●
	WRT-808A (Plug-on transmitter)	●	●	●



## WRR-802A UHF Synthesized Diversity Tuner

- Single-channel space diversity tuner, half 19-inch rack width and 1U height
- Output level control on front panel
- Use of SAW filters for exceptional rejection of unwanted signals while maintaining the best signal integrity of the desired signals
- Supplied front-mounted passive antennas
- AF, RF and battery alarm indication by both LED and LCD to double check operating condition
- Two types output connectors;
  - TRS phone balanced connector (1/4"), LINE level: -20 dBm at  $\pm 5$  kHz deviation at 1 kHz modulation
  - XLR connector, selectable output level (MIC level: -50 dBm or LINE level: -20 dBm at  $\pm 5$  kHz deviation at 1 kHz modulation)
- RK800A Rack Mount Kit Available

## MB-806A Tuner Base Unit



- Modular design, 1U height 19-inch rack unit
- Accommodates up to six WRU-806A/806B for up to six simultaneous channels of operation
- Use of AN-820A antennas and WD-820A or WD-880A antenna divider allows further multi-channel operation
- RF input attenuator switch (10 dB/0 dB)
- Balanced XLR output connector for each tuner and mix output
- Selectable output level; -58 dBm (for MIC) or -20 dBm (for LINE) at  $\pm 5$  kHz deviation at 1 kHz modulation
- Auto channel assignment of additional receiver modules for instant programming of interference-free multi-channel operation. Automatically skips unusable channels and assigns clear channels.
- Supplied passive antennas for rear mounting (with provision for front mounting)



## WRU-806B UHF Synthesized Tuner Unit

- Dedicated plug-in diversity receiver module for MB-806A tuner base unit
- Auto channel assignment for extra receiver modules with self-detection and skipping of unusable channels
- Pre-programmed groups for intermodulation free operation of multi-channel system
- AF, RF and battery alarm indication by both LED and LCD to double check operating condition
- Use of SAW filters for exceptional rejection of unwanted signals while maintaining the best signal integrity of the desired signals
- Space Diversity reception for dependable RF reception



### **WRR-862B** UHF Synthesized Dual Diversity Tuner

---

- Receives two independent RF signals simultaneously on two separate channels
- Compact and lightweight; 400 g (14.1 oz) including batteries
- Capability of operating on external power from Sony camcorders via the supplied DC cable
- Two SMC9-4S (Sony 4-pin) audio output connectors are provided on the top panel
- Switchable RF squelch; ON (5 dB $\mu$ , 10 dB $\mu$ , 15 dB $\mu$ ) or OFF
- Approximately five hours of continuous operation with four AA-size alkaline batteries
- A stereo mini jack for monitoring the output sound (switchable: Tuner 1/Tuner 2/mixed) with headphones. A monitor volume control is also included.



### **WRR-855B** UHF Synthesized Diversity Tuner

---

- Space Diversity Tuner for camcorder use
- Easily mounts onto Sony HDCAM<sup>®</sup> camcorder (HDW-750 only) or Betacam SX camcorders without need for audio/power cables or a mounting adapter
- Compact and lightweight design; 280 g (11 oz)
- Weatherproof structure
- A D-sub 15-pin connector for audio output to a Sony professional camcorder and for receiving its power supply from the HDCAM camcorder (HDW-750 only) or Betacam SX camcorder
- Use of the BTA-801 (optional portable tuner mount adapter) allows the WRR-855 to be mounted on Sony professional camcorders and powered from the camcorder via a DC cable supplied with BTA-801
- Switchable RF muting (squelch); ON (10 dB $\mu$ ) or OFF



### **WRR-810A** UHF Synthesized Portable Tuner

---

- Compact lightweight and easy to mount on Sony professional camcorders\*
- Approximately six hours of continuous operation with two AA-size alkaline batteries
- A stereo mini jack for monitoring the output sound with headphones. A built-in rotary monitor volume control is also equipped.
- Switchable RF muting (squelch); ON (15 dB $\mu$ ) or OFF

\* Supplied holder kit and attachment case is required for mounting on camcorders. When a lithium-ion battery is mounted on a camcorder, BKW-L601 battery adapter or \*A-8278-057-A mounting bracket is required.

\*Available only through Sony parts



### **WRR-805A** UHF Synthesized Portable Tuner

---

- Compact and lightweight body for use with a variety of camcorders that have a stereo mini jack for MIC input
- Flexible mounting position and direction for secure operation, for DV, DVCAM, Betacam SX and Digital Betacam. (Optional mounting bracket required for rear-mounting of up to 2 units.)
- 3.5 mm (5/32-inch) dia., 3-pole mini jack with a lock mechanism for secure camera cable clamping
- Up to six hours of continuous operation with two AA-size alkaline batteries
- Convenient headphone monitoring with volume control
- Switchable RF muting (squelch); ON (15 dB $\mu$ ) or OFF

## Common Features

- PLL frequency synthesized circuitry for highly stable operation
- Easy-to-read LCD screen and LED's showing the extensive status information

Model name	Channel number	Channel frequency in MHz	AF condition	RF condition	Battery status of tuner	Battery status of transmitter	Accumulated battery operating time
<b>WRR-862B</b>	LCD	LCD	LCD	LCD & LED	LCD	LED	LCD
<b>WRR-855B</b>	LCD	—	LED	LED	—	—	—
<b>WRR-810A</b>	LCD	—	LCD	LED	LCD	—	—
<b>WRR-805A</b>	LCD	LCD	LCD	LCD & LED	LCD	LED	LCD
<b>WRR-802A</b>	LCD	LCD	LCD & LED	LCD & LED	—	LCD & LED	—
<b>WRU-806B</b>	LCD	LCD	LCD & LED	LCD & LED	—	LCD & LED	—

## Model variations

	<b>WRR-8□□ B62/64</b> <b>WRU-806 B62/64</b> 758 MHz to 782 MHz USA TV channels 62 to 65	<b>WRR-8□□ B66/68</b> <b>WRU-806 B66/68</b> 782 MHz to 806 MHz USA TV channels 66 to 69
<b>B series</b>		
WRR-862B (Portable diversity tuner)	●	●
WRR-855B (Portable diversity tuner)	●	●
WRU-806B (Tuner module for MB-806A)	●	●

	<b>WRR-8□□ A64</b> 770 MHz to 782 MHz USA TV channels 64 to 65	<b>WRR-8□□ A66</b> 782 MHz to 794 MHz USA TV channels 66 to 67	<b>WRR-8□□ A68</b> 794 MHz to 806 MHz USA TV channels 68 to 69
<b>A series</b>			
WRR-810A (Portable tuner)	—	—	●
WRR-805A (Portable tuner)	●	●	●
WRR-802A (Rack-mountable diversity tuner)	●	●	●
MB-806A (Rack-mountable tuner base unit)	● (MB-806A can accommodate all WRU-modules from ch 62-69)		

## WD-820A UHF Antenna Divider



WD-820A rear panel

- Provides diversity output for up to four receivers
- Multi-channel operation by combination with the MB-806A and WRU-806A/806B
- Cascade output can be used for an additional antenna divider or receiver

- Two pair of antenna input connectors for up to four AN-820A antennas to expand the operating area of a wireless microphone system
- DC 9V power supply for the AN-820A UHF antennas via coaxial cable

\* The USA type operates on TV channels 62-69

## WD-880A UHF Antenna Divider



WD-880A front panel

WD-880A rear panel

- Ideal for complex, multi-channel applications from large scale live music events to TV OBs and large theater productions
- Stable reception minimizing interference and distortion
- Band pass SAW filters divide the spectrum of TV channels into multiple frequency bands, which are output from the WD-880A
- Dual inputs and outputs for diversity operation

- Switchable power supply (DC 9V or 12V) for the AN-820A UHF antennas
- LED indicators to show the output connection status
- 1 U size rack mountable

\* The USA type operates on TV channels 64-69



## AN-820A UHF Antenna

- Built-in RF amplifier (10 dB gain)
- Easy installation on a wall or on a microphone stand with the supplied stand adaptor
- Used in pairs for diversity reception
- LED indication for installation check
- External power supply provided from the MB-806A or the WD-820A/880A via coaxial cable

## Powered Mixer featuring A/V switching

### SRP-X351P Powered Mixer



- 3U rack-mountable
- Four balanced microphone inputs via rear-panel XLR connectors
- Front panel microphone input via a 1/4-inch jack (MIC 4)
- Accepts up to two WRU tuner modules routed to MIC 1 and MIC 2 inputs
- A sharp cut-off LF filter and a Signal Present LED on all four inputs
- +48V phantom power
- Three stereo inputs
- Four-way A/V source selector (ST 3)
- MIC Group bus and insertion point
- RS-232C remote and Sony Control-S remote ports
- AUX send and return
- Output MONO/STEREO switch
- Tone control and volume control for master output
- 170W per channel (4  $\Omega$ ) power amplifier
- 9V DC via antenna connectors to power optional AN-820A antennas
- Supplied wireless remote controller

# Specifications

## Hand-Held Transmitters

	<b>WRT-847B</b>	<b>WRT-867A/X</b>	<b>WRT-807A/B</b>	<b>WRT-800A</b>
Carrier frequency:	758 MHz to 782 MHz (B62/64) 782 MHz to 806 MHz (B66/68)	794 MHz to 806 MHz (A68)	770 MHz to 782 MHz (A64 A type) 782 MHz to 794 MHz (A66 A type) 794 MHz to 806 MHz (A68 A type) 758 MHz to 782 MHz (B62/64 B type) 782 MHz to 806 MHz (B66/68 B type)	794 MHz to 806 MHz (A 68 only) 94 channels selectable
Oscillator:	Crystal controlled PLL synthesizer	Crystal controlled PLL synthesizer	Crystal controlled PLL synthesizer	Crystal controlled PLL synthesizer
Type of emission:	110KF3E	110KF3E	110KF3E	110KF3E
RF power output:	10 mW/50 mW selectable (50 Ω load)	10 mW (50 Ω load)	10 mW (50 Ω load)	5 mW (50 Ω load)
Antenna:	1/4 wave length whip antenna	Helical antenna	1/4 wave length wire antenna	1/4 wave length wire antenna
Reference deviation:	±5 kHz (94 dB SPL <sup>*1</sup> , 1 kHz)	±5 kHz (94 dB SPL <sup>*1</sup> , 1 kHz)	±5 kHz (94 dB SPL <sup>*1</sup> , 1 kHz)	±5 kHz (94 dB SPL <sup>*1</sup> , 1 kHz)
Frequency response:	50 Hz to 18 kHz (typical)	40 Hz to 20 kHz (typical)	50 Hz to 15 kHz (typical)	100 Hz to 15,000 Hz
Signal-to-noise ratio:	60 dB or more (A-weighted, at reference deviation)	60 dB or more (A-weighted, at reference deviation)	60 dB or more (A-weighted, at reference deviation)	57 dB or more (A-weighted, at reference deviation)
Attenuator adjustment range (pad):	-12 dB to +9 dB variable in 3 dB steps	0, 6 dB or 12 dB switchable	0 to 21 dB, variable in 3 dB steps	—
Max. input sound pressure level:	142 dB SPL <sup>*1</sup> (with CU-F780/G780/E700/F117 at audio gain -12 dB) 120 dB SPL <sup>*1</sup> (with CU-E672)	142 dB SPL <sup>*1</sup> (with 12 dB attenuator)	151 dB SPL <sup>*1</sup> (with 21 dB attenuator)	128 dB SPL <sup>*1</sup> (at 1 kHz)
Microphone capsule:	Interchangeable (Optional)	Dynamic	Dynamic	Electret condenser
Directivity:	—	Uni-directional	Uni-directional	Uni-directional
Operating voltage:	DC 3.0 V (two AA-size alkaline batteries)	DC 1.5 V (one AA-size alkaline battery)	DC 1.5 V (one AA-size alkaline battery)	DC 1.5 V (one AA-size alkaline battery)
Battery life:	Approx. 8 hours with Sony AA-size alkaline batteries at 25 °C (77 °F) at 10 mW RF output	Approx. 4 hours with Sony AA-size alkaline batteries at 25 °C (77 °F)	Approx. 5 hours with Sony AA-size alkaline batteries at 25 °C (77 °F)	Approx. 12 hours with Sony AA-size alkaline batteries at 25 °C (77 °F)
Dimensions:	ø 37 x 150 mm (ø 1 1/2 x 6 inches)	ø 51 x 195 mm (ø 2 1/8 x 7 3/4 inches)	ø 51 x 238 mm (ø 2 1/8 x 9 3/8 inches)	ø 55 x 216 mm (ø 2 1/4 x 8 5/8 inches)
Mass:	Approx. 190 g (6.7 oz) with batteries	Approx. 325 g (11.5 oz) including battery	440 g (15.5 oz) with battery	Approx. 200 g (7.1 oz) including battery
Supplied accessories:	Microphone holder (1), channel color seal (1), softcase (1), stand adaptor (1)	Microphone holder (1), stand adaptor(1)	Microphone holder (1), Metal screw adaptor (1)	Microphone holder (1), Metal screw adaptor (1)

## Antenna Dividers

	<b>WD-820A</b>	<b>WD-880A</b>
Frequency range:	758 MHz to 806 MHz	770 MHz to 806 MHz
Channel Distribution:	Inputs: 2 pairs Outputs: 4 pairs	USA type; Inputs: 1 pair Outputs: 6 pairs (for 6 TV channels) AU type; Inputs: 2 pairs Outputs: 3 pairs
Input/output impedance:	50 Ω	50 Ω
Cascade output:	1 pair	USA type: 0 AU type: 1 pair
Power supply for Antenna booster (supplied from antenna input connectors)	DC 9V	DC 12V/9V/OFF switchable
Power consumption:	6W +outlet 300W (max.)	10W
Dimensions (W x H x D):	482 x 44 x 300 mm (19 x 1 3/4 x 11 7/8 inches)	482 x 44 x 300 mm (19 x 1 3/4 x 11 7/8 inches)
Mass:	Approx. 4.2kg (9 lb 3 oz)	Approx. 4.0kg (8 lb 13 oz)
Supplied accessories:	50 Ω BNC terminators (x6)	AC power cord (1)

## Body Pack Transmitter

	<b>WRT-822B</b>	<b>WRT-860A</b>	<b>WRT-805B</b>	<b>WRT-808A</b>
Carrier frequency:	758 MHz to 782 MHz (B62/64) 782 MHz to 806 MHz (B66/68)	770 MHz to 782 MHz (A64) 782 MHz to 794 MHz (A66) 794 MHz to 806 MHz (A68)	758 MHz to 782 MHz (B62/64) 782 MHz to 806 MHz (B66/68)	770 MHz to 782 MHz (A64) 782 MHz to 794 MHz (A66) 794 MHz to 806 MHz (A68)
Oscillator:	Crystal controlled PLL synthesizer	Crystal controlled PLL synthesizer	Crystal controlled PLL synthesizer	Crystal controlled PLL synthesizer
Type of emission:	110KF3E	110KF3E	110KF3E	110KF3E
RF power output:	10 mW (AU-type)/20 mW (USA-type) (50 Ω load)	20mW (50 Ω load)	10 mW (50 Ω load)	10 mW/50 mW selectable (50 Ω load)
Antenna:	1/4 wave length wire antenna	1/4 wave length whip antenna (SMA-J type connector)	1/4 wave length wire antenna	Internal antenna
Reference deviation:	±5 kHz (-60 dBV <sup>*2</sup> , 1 kHz)	±5 kHz (-60 dBV <sup>*2</sup> , 1 kHz)	±5 kHz (-60 dBV <sup>*2</sup> , 1 kHz input <sup>*3</sup> )	±9 kHz (-60 dBV <sup>*2</sup> , 1 kHz)
Frequency response:	70 Hz to 15 kHz (typical)	40 Hz to 20 kHz (typical)	70 Hz to 15 kHz (typical)	70 Hz to 15 kHz (typical)
Signal-to-noise ratio:	60 dB (A-weighted, at reference deviation)	60 dB or more (A-weighted, at reference deviation)	57 dB (A-weighted, at reference deviation)	67 dB or more (A-weighted, at reference deviation)
Attenuator adjustment range (pad):	0 to 21 dB, variable in 3 dB step	0 to 30 dB variable, in 3 dB steps	0 to 21 dB, variable in 3 dB steps	0 dB to 50 dB, continuous
Max. input level:	-3 dBV <sup>*2</sup> (with 21 dB attenuator)	+6 dBV <sup>*2</sup> (with 30 dB attenuator)	+17 dBV <sup>*2</sup> (-40 dBV position <sup>*4</sup> , 21 dB attenuator)	+16 dBV <sup>*2</sup>
Operating voltage:	DC 3V (two AA-size alkaline batteries)	DC 3V (two AA-size alkaline batteries)	DC 1.5V (one AA-size alkaline battery)	DC 3.0V (two AA-size alkaline batteries)
Battery life:	Approx. 6 hours (USA-type) with AA-size alkaline batteries at 25 °C (77 °F)	Approx. 6 hours with AA-size alkaline batteries at 25 °C (77 °F)	Approx. 6 hours with AA-size alkaline battery at 25 °C (77 °F)	Approx. 4 hours with AA-size alkaline batteries at 25 °C (77 °F)
Dimensions (W x H x D):	63 x 103 x 17 mm (2 1/2 x 4 1/8 x 11/16 inches)	63 x 78 x 17 mm (2 1/2 x 3 1/8 x 1 1/16 inches)	58 x 93 x 21mm (2 3/8 x 3 3/4 x 27/32 inches)	40 x 40 x 108 mm (1 5/8 x 1 5/8 x 4 3/8 inches)
Mass:	Approx. 145g (5.1 oz) including batteries	Approx. 160g (5.6 oz) including batteries	100 g (3.5 oz) including battery	175 g (6.18 oz) with batteries
Supplied accessories:	Leatherette case (1)	Leatherette case (1), spare battery case (1), microphone cable (EC-1.5CF, x 1)	—	Soft case (1)

\*1: 0 dBV SPL = 2 x 10<sup>-5</sup> Pa. \*2: 0 dBV = 1 V<sub>r.m.s.</sub> \*3: INPUT switch at -60 dBV position \*4: INPUT switch at -40 dBV position

## Tuners

	<b>WRR-862B</b>	<b>WRR-855B</b>	<b>WRR-810A</b>
Receiving channels:	2 channels	1 channel	1 channel
Receiving frequencies:	Channels within 758 MHz to 782 MHz (B62/64) Channels within 782 MHz to 806 MHz (B66/68)	758 MHz to 782 MHz (B62/64) 782 MHz to 806 MHz (B66/68)	770 MHz to 782 MHz (A64) 782 MHz to 794 MHz (A66) 794 MHz to 806 MHz (A68)
Local Oscillators:	1st: PLL synthesizer, 2nd: Crystal oscillator	1st: PLL synthesizer, 2nd: Crystal oscillator	1st: PLL synthesizer, 2nd: Crystal oscillator
De-emphasis:	50 µs	50 µs	50 µs
Reference deviation:	±5 kHz deviation at 1 kHz modulation (Maximum deviation: ±40 kHz deviation at 1 kHz modulation)	±5 kHz deviation at 1 kHz modulation (Maximum deviation: ±40 kHz deviation at 1 kHz modulation)	±5 kHz deviation at 1 kHz modulation (Maximum deviation: ±40 kHz deviation at 1 kHz modulation)
Selectivity:	60 dB or more at ±250 kHz	60 dB or more at ±250 kHz	60 dB or more at ±250 kHz
Spurious rejection:	70 dB or more	80 dB or more	50 dB or more
Frequency range:	40 Hz to 18 kHz (typical)	40 Hz to 18 kHz (typical)	70 Hz to 18 kHz
Signal-to-noise ratio:	60 dB or more (65 dB typical) at 60 dBµ RF input at reference deviation, A-weighted	60 dB or more at 60 dBµ RF input at reference deviation, A-weighted	60 dB or more at 60 dBµ RF input at reference deviation, A-weighted
RF muting (squelch) level:	5 dBµ, 10 dBµ, 15 dBµ or OFF switchable	10 dBµ or OFF selectable	15 dBµ
Audio output level:	-58 dBm at reference deviation	-40 dBm at reference deviation	-58 dBm at reference deviation
Audio output connector:	SMC9-4S (Sony 4-pin, x 2), balanced	D-sub 15-pin (1), unbalanced	SMC9-4S (Sony 4-pin), balanced
Antenna connector:	BNC-R (2), 50 Ω (nominal) impedance	BNC-R type (2), 50 Ω (nominal) impedance	BNC-R type (1), 50 Ω (nominal) impedance
Monitor connector:	3.5 mm dia. stereo mini jack (x 1, 5 mW), Tuner 1/2/mixed selectable	—	—
Operating voltage:	Batteries: DC 6 V (four AA-size alkaline batteries) External: DC 12 V	External: DC 7V	DC 3 V (two AA-size alkaline batteries)
Battery life:	Approx. 5 hours with AA-size alkaline batteries at 25 °C (77 °F)	—	Approx. 6 hours with AA-size alkaline batteries at 25 °C (77 °F)
Current (power) consumption:	Batteries: approx. 230 mA at DC 6 V External: approx. 135 mA at DC 12 V	200 mA or less at external DC 7V	180 mA or less at DC 3V
Dimensions (W x H x D):	89.0 x 120.0 x 29.5 mm (3 5/8 x 4 3/4 x 1 3/16 inches)	88.0 x 119.0 x 31.3 mm (3 1/2 x 4 3/4 x 1 1/4 inches)	63 x 120 x 17 mm (2 1/2 x 4 3/4 x 11/16 inches)
Mass:	Approx. 400 g (14.1 oz) including batteries	Approx. 280g (10.0 oz) without batteries	Approx. 220g (7.7 oz) including batteries
Supplied accessories:	Attachment case (1), camera attachment kit (1), antennas (2), output cables (2), DC cable (1)	Antennas (2)	Antenna (1), output cable (1), Holder kit for Betacam Camcorder (1), attachment case (1)



<b>WRR-805A</b>	<b>WRR-802A</b>	<b>MB-806A</b>	<b>WRU-806B</b>
1 channel	1 channel	—	1 channel
770 MHz to 782 MHz (A64) 782 MHz to 794 MHz (A66) 794 MHz to 806 MHz (A68)	770 MHz to 782 MHz (A64) 782 MHz to 794 MHz (A66) 794 MHz to 806 MHz (A68)	—	758 MHz to 782 MHz (B62/64) 782 MHz to 806 MHz (B66/68)
1st: PLL synthesizer, 2nd: Crystal oscillator	1st: PLL synthesizer, 2nd: Crystal oscillator	—	1st: PLL synthesizer, 2nd: Crystal oscillator
50 $\mu$ s	50 $\mu$ s	—	50 $\mu$ s
$\pm 5$ kHz deviation at 1 kHz modulation (Maximum deviation: $\pm 40$ kHz deviation at 1 kHz modulation)	$\pm 5$ kHz deviation at 1 kHz modulation (Maximum deviation: $\pm 40$ kHz deviation at 1 kHz modulation)	—	$\pm 5$ kHz deviation at 1 kHz modulation (Maximum deviation: $\pm 40$ kHz deviation at 1 kHz modulation)
60 dB or more at $\pm 250$ kHz	60 dB or more at $\pm 250$ kHz	—	60 dB or more at $\pm 250$ kHz
70 dB or more	70 dB or more	—	70 dB or more
70 Hz to 18 kHz (typical)	70 Hz to 18 kHz (typical)	—	70 Hz to 18 kHz (typical)
30 dB or more at 10 dB $\mu$ RF input at reference deviation, A-weighted 60 dB or more at 60 dB $\mu$ RF input at reference deviation, A-weighted	60 dB or more at 60 dB $\mu$ RF input at reference deviation, A-weighted	—	60 dB or more at 60 dB $\mu$ RF input at reference deviation, A-weighted
15 dB $\mu$ $\pm 5$ dB $\mu$	30 dB $\mu$	—	30 dB $\mu$
-58 dBm at reference deviation	-20 dBm/-58 dBm at reference deviation	-20 dBm/-58dBm at reference deviation	—
3.5 mm (5/32 inch) 3-pole mini phone jack with a lock mechanism, balanced	XLR-3-32 (1), balanced, and TRS phone (1, 6.3 mm (1/4 inch) dia.), balanced	XLR-3-32 (7), balanced	—
—	BNC-R type (2), 50 $\Omega$ (nominal) impedance	BNC-R type (2), 50 $\Omega$ (nominal) impedance	—
3.5 mm dia. 3-pole stereo mini phone jack	—	—	—
DC 3 V (two AA-size alkaline batteries)	DC 9 V	AC 120 V, 60 Hz (USA-type)	DC 9V
Approx. 5 hours with AA-size alkaline batteries at 25 °C (77 °F) 205 mA or less at DC 3V	— 600 mA or less	— 30 W	— 225 mA or less
44 x 121 x 24 mm (1 3/4 x 4 7/8 x 31/32 inches)	218 x 44 x 210 mm (8 5/8 x 1 3/4 x 8 3/8 inches)	482 x 44 x 300 mm (19 x 1 3/4 x 11 7/8 inches)	57 x 26 x 122 mm (2 1/4 x 1 1/16 x 4 7/8 inches)
Approx. 140 g (4.9 oz) including batteries Attachment case with a belt clip (1), output cable (1)	1.6 kg (3 lb 8 oz) AC power adaptor (1), antenna (2)	3.6 kg (7 lb 15 oz) AC power cord (1), antennas (2)	160 g (5.7 oz) —



## ECM-44 series

### Lavalier Microphones

- Omni-directional, electret condenser microphone
- Superior sound quality
- Frequency response: 40 Hz to 15 kHz
- Sensitivity: -40 dB SPL (10 mV) (0 dB = 1V/Pa, at 1 kHz)
- Microphone head: 8.5 mm (11/32 inch) dia. X 14.5 mm (19/32 inches), approx. 2 g (0.07 oz)
- Cable length: 1.2 m (3.9 feet)
- Supplied accessories: holder clip (1, single/horizontal type), Urethane wind screen (1), microphone case (1)
- Two types of connections available;
  - ECM-44BC;** Supplied with SMC9-4S connector for use with WRT-822A/822B/860A
  - ECM-44BMP;** Supplied with 3-pole Mini Jack with a stable lock mechanism for use with WRT-805A/805B



## ECM-55 Series

### Lavalier Microphones

- Uni-directional electret condenser microphone
- Frequency response tailored for enhanced presence and improved voice quality in lavalier applications
- Frequency response: 30 Hz to 18 kHz
- Sensitivity: -38.5 dB (11.9 mV) (0 dB = 1V/Pa, at 1 kHz)
- Microphone head: 10.6 dia. x 21 mm (7/16 dia. x 27/32 inch) approx. 6.5 g (0.2 oz)
- Supplied accessories: Holder clip (1), Metal-mesh wind screen (1)
- Two types of connections are available:
  - ECM-55BPT;** 3.0 m (9.8 feet) cable without battery or connector (pig tail connection)
  - ECM-55BC;** 1.2 m (3.9 feet) cable terminating in SMC9-4P type connector for use with WRT-822B/860A



## ECM-66 Series

### Lavalier Microphones

- Uni-directional electret condenser microphone
- Designed for instrumental applications
- Frequency response: 70 Hz to 14 kHz
- Sensitivity: -36.5 dB (15 mV) (0 dB = 1V/Pa, at 1 kHz)
- Microphone head: 10.6 dia. x 24.2 mm (7/16 dia. x 31/32 inch) approx. 7.0 g (0.3 oz)
- Supplied accessories: Holder clip (1), Urethane wind screen (1)
- Two types of connections are available:
  - ECM-66BPT;** 3.0 m (9.8 feet) cable without battery or connector (pig tail connection)
  - ECM-66BC;** 1.2 m (3.9 feet) cable terminating in SMC9-4P type connector for use with WRT-822B/860A



## ECM-77 series

### Lavalier Microphones

- High performance, ultra miniature, microphone
- Omni-directional, electret condenser microphone
- Frequency response: 40 Hz to 20 kHz
- Sensitivity: -39.0 dB (11.2 mV) (0 dB = 1V/Pa, at 1 kHz)
- Microphone head: 5.6 mm (1/4 inch) dia. x 12.5 mm (1/2 inches), approx. 1.5g (0.05 oz)
- Cable length: 1.2 m (3.9 feet)
- Supplied accessories: holder clips (2, single/horizontal type and single/vertical type), Metal-mesh wind screen (1), microphone case (1)
- Two types of connections available:
  - ECM-77BC/FC;** Supplied with SMC9-4S connector for use with WRT-822A/822B/860A
  - ECM-77BMP;** Supplied with 3-pole Mini Jack with a stable lock mechanism for use with WRT-805A/805B

## EC-0.4CM

### SMC9-4P

- XLR male adapter cable

## A-8278-057-A

### Bracket (available only through Sony Service Parts)

- For mounting any Sony portable tuner (with tuner supplied hardware) to most Sony professional camcorders which work with Sony Lithium-Ion batteries

## EC-1.5CF

### Microphone Cable

- Fitted with an XLR female connector and SMC9-4P connector
- Allows a microphone with a 3-pin male XLR output connector to be connected to WRT-822A/822B/860A transmitter
- Cable length: 1.5 m (4.9 feet)

## GC-0.7MP/1 Guitar Cable

- Used with WRT-805A/805B Body Pack Transmitter
- Special active guitar cable for high quality re-production of guitar sound
- 3-pole mini plug with a lock mechanism for secure cable clamping
- 5.5 mm (7/32 inch) dia. x 0.7 m (2.3 feet)

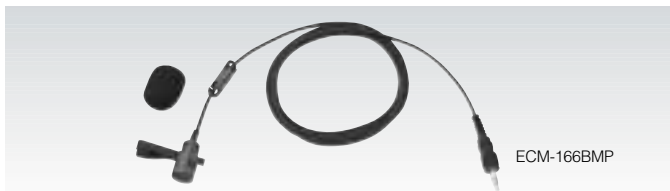

## ECM-166BMP series

### Lavalier Microphones

- Uni-directional, electret condenser microphone
- Resistant to howling by rejecting indirect sound
- Ideal for institutional uses and sound contracting applications such as speeches, lectures and conferences
- Frequency response: 100 Hz to 10 kHz
- Sensitivity: -45 dB (5.6 mV) (0 dB = 1V/Pa, at 1 kHz)
- Microphone head: 12.5 mm (1/2 inch) dia. x 23.5 mm (15/16 inches), approx. 3.5 g (0.12 oz)
- Cable length: 1.2 m (3.9 feet)
- Supplied accessories: Urethane wind screen (1), holder clip (1)
- Two types of connections available:
  - ECM-166BC;** Supplied with SMC9-4S connector for use with WRT-822A/822B/860A
  - ECM-166BMP;** Supplied with 3-pole Mini Jack with a stable lock mechanism for use with WRT-805A/805B



## ECM-310 series

### Headset Microphones

- Lightweight, headset-style microphone for sound reinforcement applications
- Wide-cardioid, electret condenser microphone provides crisp and clear sound while isolating desired sound from surrounding ambience
- Adjustable hinge and goose-neck
- Frequency response: 70 Hz to 12 kHz
- Sensitivity: -44 dB (6.3 mV)  $\pm 3$  dB (0 dB = 1V/Pa, at 1 kHz)
- Cable length: 1.2 m (3.9 feet)
- Supplied accessory: Urethane wind screen (1)
- Two types of connections available:
  - ECM-310BC;** Supplied with SMC9-4S connector for use with WRT-822A/822B/860A
  - ECM-310BMP;** Supplied with 3-pole Mini Jack with a stable lock mechanism for use with WRT-805A/805B



## BTA-801

### Portable Tuner Mount Adaptor

- Allows a WRR-855A/855B to be mounted on a Sony professional camcorder
- Supplies DC power from a camcorder to the WRR-855A/855B via an incorporated DC/DC converter



## CA-WR855

### Camera Adaptor

- Enables a WRR-855A/855B to be mounted on Sony DSR-300/300P/500WS/500WSP DVCAM camcorders with direct audio/power connection interfaces

## K-1161

### Guitar Cable

- Used with the WRT-822A/822B or WRT-860A
- Special active guitar cable
- Incorporates an impedance converter FET
- 6.3mm dia. (1/4 inch dia.) 2-pole phone jack to SMC9-4P connector with lock function
- Cable length: 0.7 m (2.3 feet)

## K-1334

### BMP-XLR Conversion Cable (Balanced) for WRR-805A

- BMP (3.5 mm dia. (5/32 inch dia.) 3-pole mini phone jack with a lock function  $\leftrightarrow$  XLR male connector
- Cable length: 460 mm (1.5 feet)

## K-1314

### Passive 1/4 wave antennas

## K-1324

### BMP Plug

- Used for connecting a wired microphone to the WRT-805A/805B transmitter or as an audio cable plug for connection to the WRR-805A portable tuner
- 3-pole mini plug with a lock mechanism

## LCS-T805 Soft Case

- Holding WRT-805A/805B Body Pack Transmitter to be attached to a guitar strap
- Guitar strap width: 15 mm (19/32 inch) to 70 mm (2 7/8 inches)

## RK-800A

- Rack mount kit for WRR-802A

## WBC Coaxial Cables

- 50 $\Omega$  coaxial cables, fitted with BNC connectors at both ends
- Interconnect antennas, dividers and rack-mountable receivers
- Five types of cable length available;
  - WBC-0.3B-P;** 0.3 m (1.0 feet)
  - WBC-0.6B-P;** 0.6 m (2.0 feet)
  - WBC-10B-5P;** 10 m (32.8 feet)
  - WBC-20B-5P;** 20 m (65.6 feet)
  - WBC-30B-5P;** 30 m (98.4 feet)

## Multi-channel simultaneous operation

The Sony wireless microphone system allows a wide variety of multi-channel systems to be flexibly configured to meet individual requirements.

The number of channels that can be simultaneously operated using **Either B62/64 or B66/68 models** (without use of a WD-880A) is as follows;

\*For the B-series model variations, please refer to the "Model variation" charts on the pages 8 and 11.

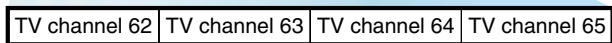
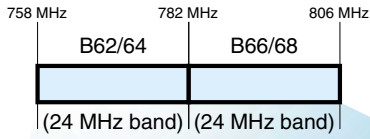

When all four TV channels are available, up to 16-channel simultaneous operation is possible.

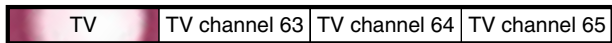

or



or

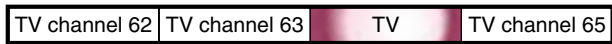

or

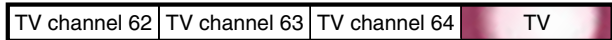

When three of four TV channels are available, up to 13-channel simultaneous operation is possible.

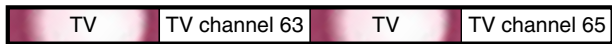

or



When either the even or the odd TV channels are available, up to 11-channel simultaneous operation is possible.

The number of channels that can be simultaneously operated using **A combination of B62/64 and B66/68 models** (without use of a WD-880A) is as follows;

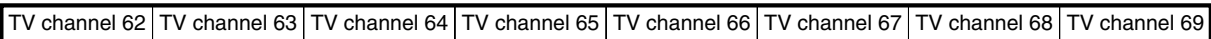

When all eight TV channels are available, up to 22-channel simultaneous operation is possible.

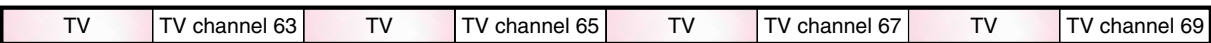

or



When either all even or all odd TV channels are available, up to 16-channel simultaneous operation is possible.

The number of channels that can be simultaneously operated using  
**Any one A series model 64, or 66 or 68\* Products**

(without use of a WD-880A) is as follows;

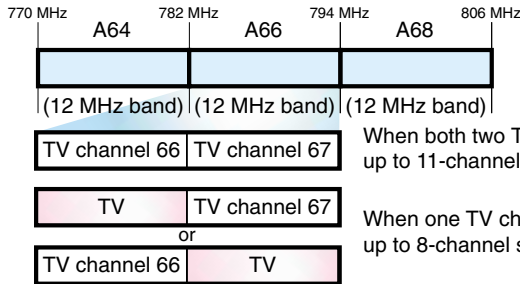

When both two TV channels are available, up to 11-channel simultaneous operation is available.

When one TV channels is available, up to 8-channel simultaneous operation is possible.

\*For the A-series model variations, please refer to the "Model variation" charts on the pages 8 and 11.

The number of channels that can be simultaneously operated using any

**Two of the Three A-series models 64, 66, 68** (without use of a WD-880A) is as follows;

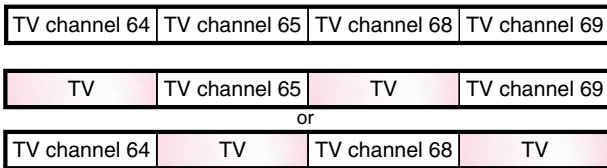

When all four channels are available, up to 16-channel simultaneous operation is possible.

When either all even or all odd TV channels are available, up to 11-channel simultaneous operation is possible.

The number of channels that can be simultaneously operated using

**All three A series models on 64, 66 and 68 Combination**

(without use of a WD-880A) is as follows;

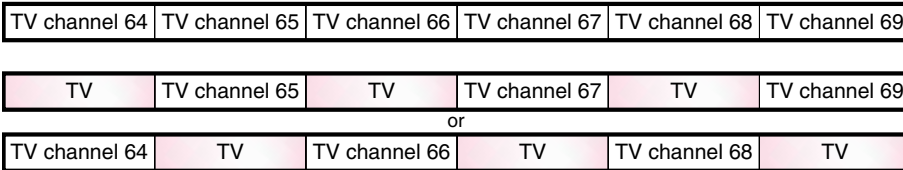

When all eight TV channels are available, up to 19-channel simultaneous operation is possible.

When either all even or all odd TV channels are available, up to 13-channel simultaneous operation is possible.

# Frequency Lists

## A64

64-01	770.125	65-01	776.125
64-02	770.250	65-02	776.250
64-03	770.375	65-03	776.375
64-04	770.500	65-04	776.500
64-05	770.625	65-05	776.625
64-06	770.750	65-06	776.750
64-07	770.875	65-07	776.875
64-08	771.000	65-08	777.000
64-09	771.125	65-09	777.125
64-10	771.250	65-10	777.250
64-11	771.375	65-11	777.375
64-12	771.500	65-12	777.500
64-13	771.625	65-13	777.625
64-14	771.750	65-14	777.750
64-15	771.875	65-15	777.875
64-16	772.000	65-16	778.000
64-17	772.125	65-17	778.125
64-18	772.250	65-18	778.250
64-19	772.375	65-19	778.375
64-20	772.500	65-20	778.500
64-21	772.625	65-21	778.625
64-22	772.750	65-22	778.750
64-23	772.875	65-23	778.875
64-24	773.000	65-24	779.000
64-25	773.125	65-25	779.125
64-26	773.250	65-26	779.250
64-27	773.375	65-27	779.375
64-28	773.500	65-28	779.500
64-29	773.625	65-29	779.625
64-30	773.750	65-30	779.750
64-31	773.875	65-31	779.875
64-32	774.000	65-32	780.000
64-33	774.125	65-33	780.125
64-34	774.250	65-34	780.250
64-35	774.375	65-35	780.375
64-36	774.500	65-36	780.500
64-37	774.625	65-37	780.625
64-38	774.750	65-38	780.750
64-39	774.875	65-39	780.875
64-40	775.000	65-40	781.000
64-41	775.125	65-41	781.125
64-42	775.250	65-42	781.250
64-43	775.375	65-43	781.375
64-44	775.500	65-44	781.500
64-45	775.625	65-45	781.625
64-46	775.750	65-46	781.750
64-47	775.875	65-47	781.875

## A66

66-01	782.125	67-01	788.125
66-02	782.250	67-02	788.250
66-03	782.375	67-03	788.375
66-04	782.500	67-04	788.500
66-05	782.625	67-05	788.625
66-06	782.750	67-06	788.750
66-07	782.875	67-07	788.875
66-08	783.000	67-08	789.000
66-09	783.125	67-09	789.125
66-10	783.250	67-10	789.250
66-11	783.375	67-11	789.375
66-12	783.500	67-12	789.500
66-13	783.625	67-13	789.625
66-14	783.750	67-14	789.750
66-15	783.875	67-15	789.875
66-16	784.000	67-16	790.000
66-17	784.125	67-17	790.125
66-18	784.250	67-18	790.250
66-19	784.375	67-19	790.375
66-20	784.500	67-20	790.500
66-21	784.625	67-21	790.625
66-22	784.750	67-22	790.750
66-23	784.875	67-23	790.875
66-24	785.000	67-24	791.000
66-25	785.125	67-25	791.125
66-26	785.250	67-26	791.250
66-27	785.375	67-27	791.375
66-28	785.500	67-28	791.500
66-29	785.625	67-29	791.625
66-30	785.750	67-30	791.750
66-31	785.875	67-31	791.875
66-32	786.000	67-32	792.000
66-33	786.125	67-33	792.125
66-34	786.250	67-34	792.250
66-35	786.375	67-35	792.375
66-36	786.500	67-36	792.500
66-37	786.625	67-37	792.625
66-38	786.750	67-38	792.750
66-39	786.875	67-39	792.875
66-40	787.000	67-40	793.000
66-41	787.125	67-41	793.125
66-42	787.250	67-42	793.250
66-43	787.375	67-43	793.375
66-44	787.500	67-44	793.500
66-45	787.625	67-45	793.625
66-46	787.750	67-46	793.750
66-47	787.875	67-47	793.875

## A68

68-01	794.125	69-01	800.125
68-02	794.250	69-02	800.250
68-03	794.375	69-03	800.375
68-04	794.500	69-04	800.500
68-05	794.625	69-05	800.625
68-06	794.750	69-06	800.750
68-07	794.875	69-07	800.875
68-08	795.000	69-08	801.000
68-09	795.125	69-09	801.125
68-10	795.250	69-10	801.250
68-11	795.375	69-11	801.375
68-12	795.500	69-12	801.500
68-13	795.625	69-13	801.625
68-14	795.750	69-14	801.750
68-15	795.875	69-15	801.875
68-16	796.000	69-16	802.000
68-17	796.125	69-17	802.125
68-18	796.250	69-18	802.250
68-19	796.375	69-19	802.375
68-20	796.500	69-20	802.500
68-21	796.625	69-21	802.625
68-22	796.750	69-22	802.750
68-23	796.875	69-23	802.875
68-24	797.000	69-24	803.000
68-25	797.125	69-25	803.125
68-26	797.250	69-26	803.250
68-27	797.375	69-27	803.375
68-28	797.500	69-28	803.500
68-29	797.625	69-29	803.625
68-30	797.750	69-30	803.750
68-31	797.875	69-31	803.875
68-32	798.000	69-32	804.000
68-33	798.125	69-33	804.125
68-34	798.250	69-34	804.250
68-35	798.375	69-35	804.375
68-36	798.500	69-36	804.500
68-37	798.625	69-37	804.625
68-38	798.750	69-38	804.750
68-39	798.875	69-39	804.875
68-40	799.000	69-40	805.000
68-41	799.125	69-41	805.125
68-42	799.250	69-42	805.250
68-43	799.375	69-43	805.375
68-44	799.500	69-44	805.500
68-45	799.625	69-45	805.625
68-46	799.750	69-46	805.750
68-47	799.875	69-47	805.875

## B62/64

62-01	758.125	63-01	764.125	64-01	770.125	65-01	776.125
62-02	758.250	63-02	764.250	64-02	770.250	65-02	776.250
62-03	758.375	63-03	764.375	64-03	770.375	65-03	776.375
62-04	758.500	63-04	764.500	64-04	770.500	65-04	776.500
62-05	758.625	63-05	764.625	64-05	770.625	65-05	776.625
62-06	758.750	63-06	764.750	64-06	770.750	65-06	776.750
62-07	758.875	63-07	764.875	64-07	770.875	65-07	776.875
62-08	759.000	63-08	765.000	64-08	771.000	65-08	777.000
62-09	759.125	63-09	765.125	64-09	771.125	65-09	777.125
62-10	759.250	63-10	765.250	64-10	771.250	65-10	777.250
62-11	759.375	63-11	765.375	64-11	771.375	65-11	777.375
62-12	759.500	63-12	765.500	64-12	771.500	65-12	777.500
62-13	759.625	63-13	765.625	64-13	771.625	65-13	777.625
62-14	759.750	63-14	765.750	64-14	771.750	65-14	777.750
62-15	759.875	63-15	765.875	64-15	771.875	65-15	777.875
62-16	760.000	63-16	766.000	64-16	772.000	65-16	778.000
62-17	760.125	63-17	766.125	64-17	772.125	65-17	778.125
62-18	760.250	63-18	766.250	64-18	772.250	65-18	778.250
62-19	760.375	63-19	766.375	64-19	772.375	65-19	778.375
62-20	760.500	63-20	766.500	64-20	772.500	65-20	778.500
62-21	760.625	63-21	766.625	64-21	772.625	65-21	778.625
62-22	760.750	63-22	766.750	64-22	772.750	65-22	778.750
62-23	760.875	63-23	766.875	64-23	772.875	65-23	778.875
62-24	761.000	63-24	767.000	64-24	773.000	65-24	779.000
62-25	761.125	63-25	767.125	64-25	773.125	65-25	779.125
62-26	761.250	63-26	767.250	64-26	773.250	65-26	779.250
62-27	761.375	63-27	767.375	64-27	773.375	65-27	779.375
62-28	761.500	63-28	767.500	64-28	773.500	65-28	779.500
62-29	761.625	63-29	767.625	64-29	773.625	65-29	779.625
62-30	761.750	63-30	767.750	64-30	773.750	65-30	779.750
62-31	761.875	63-31	767.875	64-31	773.875	65-31	779.875
62-32	762.000	63-32	768.000	64-32	774.000	65-32	780.000
62-33	762.125	63-33	768.125	64-33	774.125	65-33	780.125
62-34	762.250	63-34	768.250	64-34	774.250	65-34	780.250
62-35	762.375	63-35	768.375	64-35	774.375	65-35	780.375
62-36	762.500	63-36	768.500	64-36	774.500	65-36	780.500
62-37	762.625	63-37	768.625	64-37	774.625	65-37	780.625
62-38	762.750	63-38	768.750	64-38	774.750	65-38	780.750
62-39	762.875	63-39	768.875	64-39	774.875	65-39	780.875
62-40	763.000	63-40	769.000	64-40	775.000	65-40	781.000
62-41	763.125	63-41	769.125	64-41	775.125	65-41	781.125
62-42	763.250	63-42	769.250	64-42	775.250	65-42	781.250
62-43	763.375	63-43	769.375	64-43	775.375	65-43	781.375
62-44	763.500	63-44	769.500	64-44	775.500	65-44	781.500
62-45	763.625	63-45	769.625	64-45	775.625	65-45	781.625
62-46	763.750	63-46	769.750	64-46	775.750	65-46	781.750
62-47	763.875	63-47	769.875	64-47	775.875	65-47	781.875

## B66/68

66-01	782.125	67-01	788.125	68-01	794.125	69-01	800.125
66-02	782.250	67-02	788.250	68-02	794.250	69-02	800.250
66-03	782.375	67-03	788.375	68-03	794.375	69-03	800.375
66-04	782.500	67-04	788.500	68-04	794.500	69-04	800.500
66-05	782.625	67-05	788.625	68-05	794.625	69-05	800.625
66-06	782.750	67-06	788.750	68-06	794.750	69-06	800.750
66-07	782.875	67-07	788.875	68-07	794.875	69-07	800.875
66-08	783.000	67-08	789.000	68-08	795.000	69-08	801.000
66-09	783.125	67-09	789.125	68-09	795.125	69-09	801.125
66-10	783.250	67-10	789.250	68-10	795.250		

### Channel Plan for B Version Models 62/64

<b>Group 01: 8-channel group</b>		65 - 44	781.500	64 - 28	773.500
62 - 01	758.125	65 - 46	781.750	64 - 35	774.375
62 - 05	758.625	<b>Group 05: 11-channel group</b>		64 - 38	774.750
62 - 11	759.375	62 - 07	758.875	64 - 40	775.000
62 - 25	761.125	62 - 09	759.125	<b>Group 08: 11-channel group</b>	
62 - 28	761.500	62 - 12	759.500	63 - 08	765.000
62 - 36	762.500	62 - 19	760.375	63 - 10	765.250
62 - 41	763.125	62 - 33	762.125	63 - 13	765.625
62 - 43	763.375	62 - 37	762.625	63 - 20	766.500
<b>Group 02: 8-channel group</b>		63 - 02	764.250	63 - 34	768.250
63 - 03	764.375	63 - 08	765.000	63 - 38	768.750
63 - 13	765.625	63 - 24	767.000	65 - 03	776.375
63 - 18	766.250	63 - 35	768.375	65 - 09	777.125
63 - 26	767.250	63 - 44	769.500	65 - 25	779.125
63 - 37	768.625	<b>Group 06: 11-channel group</b>		65 - 36	780.500
63 - 40	769.000	64 - 05	770.625	65 - 45	781.625
63 - 44	769.500	64 - 14	771.750	<b>Group 09: 16-channel group</b>	
63 - 46	769.750	64 - 25	773.125	62 - 03	758.375
<b>Group 03: 8-channel group</b>		64 - 41	775.125	62 - 05	758.625
64 - 01	770.125	64 - 47	775.875	62 - 08	759.000
64 - 05	770.625	64 - 12	771.500	62 - 12	759.500
64 - 11	771.375	65 - 16	778.000	62 - 34	762.250
64 - 25	773.125	65 - 30	779.750	63 - 01	764.125
64 - 28	773.500	65 - 37	780.625	63 - 20	766.500
64 - 36	774.500	65 - 40	781.000	63 - 37	768.625
64 - 41	775.125	65 - 42	781.250	64 - 02	770.250
64 - 43	775.375	<b>Group 07: 11-channel group</b>		64 - 27	773.375
<b>Group 04: 8-channel group</b>		62 - 03	758.375	64 - 47	775.875
65 - 03	776.375	62 - 12	759.500	65 - 11	777.375
65 - 13	777.625	62 - 23	760.875	65 - 22	778.750
65 - 18	778.250	62 - 39	762.875	65 - 32	780.000
65 - 26	779.250	62 - 45	763.625	65 - 38	780.750
65 - 37	780.625	64 - 10	771.250	65 - 46	781.750
65 - 40	781.000	64 - 14	771.750		

### 22 Channel Plan

No.	Channel	Frequency (MHz)
1	6206	758.750
2	6212	759.500
3	6228	761.500
4	6230	761.750
5	6301	764.125
6	6314	765.750
7	6405	770.625
8	6436	774.500
9	6447	775.875
10	6508	777.000
11	6534	780.250
12	6615	783.875
13	6627	785.375
14	6724	791.000
15	6739	792.875
16	6747	793.875
17	6824	797.000
18	6829	797.625
19	6925	803.125
20	6935	804.375
21	6939	804.875
22	6942	805.250

### Channel Plan for B Version Models 66/68

<b>Group 01: 8-channel group</b>		69 - 44	805.500	68 - 28	797.500
66 - 01	782.125	69 - 46	805.750	68 - 35	798.375
66 - 05	782.625	<b>Group 05: 11-channel group</b>		68 - 38	798.750
66 - 11	783.375	66 - 07	782.875	68 - 40	799.000
66 - 25	785.125	66 - 09	783.125	<b>Group 08: 11-channel group</b>	
66 - 28	785.500	66 - 12	783.500	67 - 08	789.000
66 - 36	786.500	66 - 19	784.375	67 - 10	789.250
66 - 41	787.125	66 - 33	786.125	67 - 13	789.625
66 - 43	787.375	66 - 37	786.625	67 - 20	790.500
<b>Group 02: 8-channel group</b>		67 - 02	788.250	67 - 34	792.250
67 - 03	788.375	67 - 08	789.000	67 - 38	792.750
67 - 13	789.625	67 - 24	791.000	69 - 03	800.375
67 - 18	790.250	67 - 35	792.375	69 - 09	801.125
67 - 26	791.250	67 - 44	793.500	69 - 25	803.125
67 - 37	792.625	<b>Group 06: 11-channel group</b>		69 - 36	804.500
67 - 40	793.000	68 - 05	794.625	69 - 45	805.625
67 - 44	793.500	68 - 14	795.750	<b>Group 09: 16-channel group</b>	
67 - 46	793.750	68 - 25	797.125	66 - 03	782.375
<b>Group 03: 8-channel group</b>		68 - 41	799.125	66 - 05	782.625
68 - 01	794.125	68 - 47	799.875	66 - 08	783.000
68 - 05	794.625	68 - 12	795.500	66 - 12	783.500
68 - 11	795.375	69 - 16	802.000	66 - 34	786.250
68 - 25	797.125	69 - 30	803.750	67 - 01	788.125
68 - 28	797.500	69 - 37	804.625	67 - 20	790.500
68 - 36	798.500	69 - 40	805.000	67 - 37	792.625
68 - 41	799.125	69 - 42	805.250	68 - 02	794.250
68 - 43	799.375	<b>Group 07: 11-channel group</b>		68 - 27	797.375
<b>Group 04: 8-channel group</b>		66 - 03	782.375	68 - 47	799.875
69 - 03	800.375	66 - 12	783.500	69 - 11	801.375
69 - 13	801.625	66 - 23	784.875	69 - 22	802.750
69 - 18	802.250	66 - 39	786.875	69 - 32	804.000
69 - 26	803.250	66 - 45	787.625	69 - 38	804.750
69 - 37	804.625	68 - 10	795.250	69 - 46	805.750
69 - 40	805.000	68 - 14	795.750		

---

Sony Electronics Inc.  
One Sony Drive  
Park Ridge, NJ 07656  
[www.sony.com/proaudio](http://www.sony.com/proaudio)

Use of Sony wireless devices in the United States of America is regulated by the Federal Communications Commission as described in Part 15 and 74 of the FCC regulations and users authorized thereby are required to obtain an appropriate license.

©2001 Sony Corporation. All rights reserved.

Reproduction in whole or in part without written permission is prohibited.

Features and specifications are subject to change without notice.

All non-metric weights and measures are approximate.  
Sony, Betacam SX, Digital Betacam and HDCAM are trademarks of Sony.