

CATEGORY 5E WALL MOUNT PATCH PANEL

PPW1-12-8P8C-C5e

Hyperline
CABLING SYSTEMS

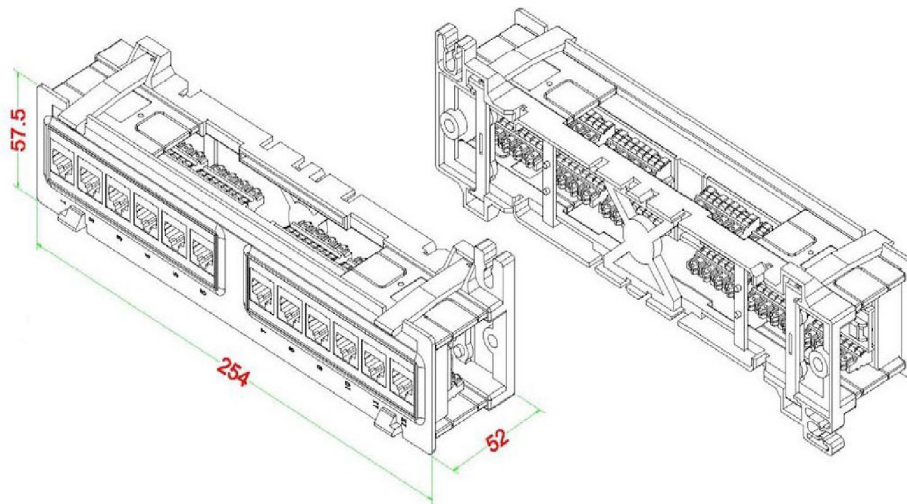

PRODUCT DESCRIPTION

- Horizontal 10" Wall Panel for Mounting in 89D Bracket
- This patch panel is designed for 22-26 AWG solid conductors
- Horizontal termination with 110 single punch tool installation
- Performance: Meets Category 5e EIA/TIA 568B Standard

CONSTRUCTION CHARACTERISTICS

- Color marking of conductors according to T568B and T568A
- Numeral marking of ports on the front side of the panel
- Space for additional marking
- Color and numeral marking of IDC modules on the rear side of the panel
- Hyperline patch cord usage provides the best connection
- 110 type punch down tool is used for cable termination
- Performance: Meets C5e EIA/TIA 568B Standard
- Meets TIA/EIA TSB-40
- Meets ISO/IEC Generic Cabling Standard 11801
- Meets CENELEC Generic Cabling Standard EN50173

MECHANICAL CHARACTERISTICS

IDC Punch Down Cycle:	Over 250 Cycles (min.)
Jack Insertion Cycle:	Over 2000 Cycles (min.)
Operation Temperature:	-40 °C – +70 °C

MATERIAL CHARACTERISTICS

Front Plate:	Fireproof ABS UL-94V0
IDC:	Phosphor Bronze and Fireproof UL-94V0 PCT(PC+PBT)
PCB:	FR-4 / UL-94V0
Contacts:	Phosphor Bronze 8P8C & 50 micro inches gold plated
89D Bracket:	ABS

ELECTRICAL CHARACTERISTICS

Insulation Resistance	500M ohms (min.)
Contact Resistance	20m ohms
Current Rating	1.5 Amps
DC Resistance	0.1 ohms (max.)
Dielectric withstand voltage	1000 V AC RMS, 60Hz/1min

ORDERING

PPW1-12-8P8C-C5e	Patch Panel 10", 1U, 12-port RJ-45, category 5e, 110 IDC
------------------	--